

JKS[®]

Installation Instructions

Product: Adjustable Trackbar

Part Number: PN OGS151

Welcome

CONGRATULATIONS on purchasing a new Adjustable Trackbar from JKS Manufacturing. We are committed to providing you with the best products available and your satisfaction is our first priority.

PLEASE READ these Installation Instructions carefully, and save them for future reference, as they contain important installation and maintenance information.

Important

VEHICLE MUST BE EQUIPPED with a CV type driveshaft.

NOT COMPATIBLE WITH right hand drive vehicles.

CHECK TORQUE SPECIFICATIONS regularly.

Tools Required

- Hydraulic Floor Jack & Jack Stands
- Metric/Standard Socket Wrench Set
- Torque Wrench
- 1-7/16" Open-End Wrench
- T55 Torx Driver * (for OE track bar bolt)
- Tape Measure
- Heavy Duty Ratchet Strap *
- Anti-Seize Lubricant
- Wheel Bearing Grease
- Hydraulic Press *
- Angled CV Track Bar Bracket *

* Asterisk denotes tools that are not required for some applications. Thoroughly read instructions first to determine which tools will be required for your application.

Parts

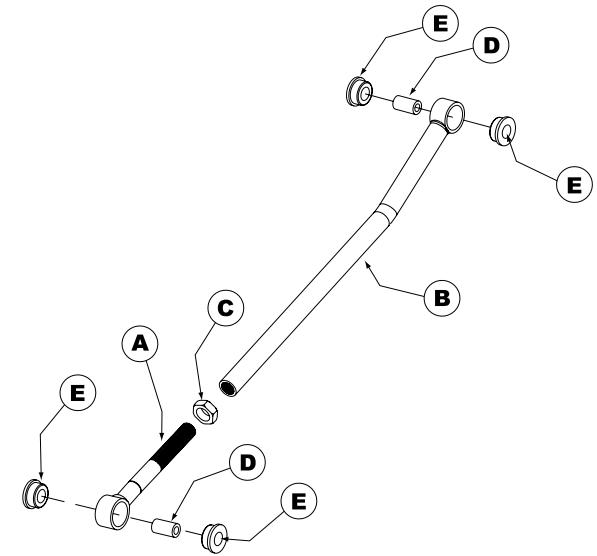

	DESCRIPTION	QTY
A	Male Threaded (Axle) End	1
B	Female Threaded (Chassis) End	1
C	1" NF Jam Nut	1
D	Bushing Sleeve	2
E	Polyurethane Bushing	4

Installation

❑ 1. REMOVE REAR TRACK BAR

- Raise and support vehicle chassis with jack stands positioned in front of the rear lower suspension arm brackets. Remove rear wheels from vehicle.
- Raise and support axle housing with a hydraulic jack. **HINT:** To relieve tension from mounting bolts, axle should be evenly supported with suspension at normal ride height.
- If equipped, remove and discard plastic dust shield covering the bolt that secures rear track bar to the OE bracket.
- Remove rear track bar mounting hardware from axle and chassis brackets. **HINT:** A T55 Torx driver may be required to remove hardware.
- Remove track bar from vehicle and retain hardware. **HINT:** The original track bar bushings may be retained as spares for your Adjustable Trackbar if replacement parts are ever needed. See Maintenance section for details.

❑ 2. INSTALL ANGLED CV TRACK BAR BRACKET (OPTIONAL)

If Adjustable Trackbar PN OGS151B was ordered, a special Angled CV Bracket PN OGS160 was also supplied. The purpose of this bracket is to re-establish proper alignment of the axle bracket with the track bar. This is necessary whenever the axle is rotated to align the pinion with a CV type driveshaft.

- If vehicle has already been equipped with a similar aftermarket angled track bar bracket, disregard this step and proceed to next section.
- Install JKS Angled CV Track Bar Bracket PN OGS160 (or equivalent) at this time, according to the installation instructions provided with the part.

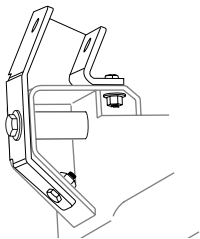

IMPORTANT:
PN OGS160 is supplied with JKS Adjustable Trackbar PN OGS151B, or available separately if installing PN OGS151.

❑ 3. LUBRICATE BUSHINGS AT EACH END OF ADJUSTABLE TRACKBAR

- Locate bag of parts containing Polyurethane Bushings (E) and Sleeves (D).
- Liberally apply wheel bearing grease to surface of bushings.
- Assemble Polyurethane Bushings (E) and Sleeves (D) at each end of Adjustable Trackbar as indicated in the parts diagram on page 1.

❑ 4. MOUNT ADJUSTABLE TRACKBAR TO CHASSIS RAIL BRACKET

- Apply anti-seize lubricant to bolt threads of original track bar mounting hardware.
- Mount Chassis End (B) of Adjustable Trackbar to the chassis rail bracket and loosely install the original mounting hardware. **HINT:** When installed correctly, the bend in Adjustable Trackbar should point up.

Chassis Rail
Bracket

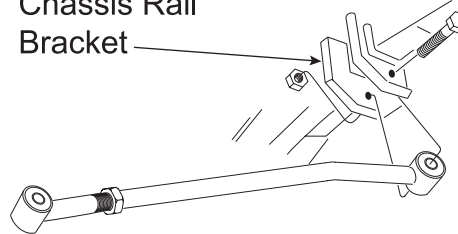

❑ 5. CENTER REAR AXLE HOUSING

The rear axle housing must be in perfect lateral alignment with vehicle chassis before Adjustable Trackbar installation can be completed.

- Re-install wheels and lower vehicle to ground.

IMPORTANT: Vehicle must be at normal ride height, on level ground, with the suspension supporting the full vehicle weight.

- Determine if the axle housing is centered by measuring the distance between the tire and chassis, using the exact same points on each side of the vehicle to ensure accuracy.



HINT: For example, measure from the edge of a tire tread lug to the outboard side of the chassis, then repeat the measurement on the other side of vehicle using exact same points.

- If the two measurements are equal, the axle is centered. If the measurements vary, divide the difference in half to determine the amount of adjustment required. **HINT:** If the axle housing is not centered, the chassis can be laterally shifted using either of the following methods.

Ratchet Strap (preferred)

- Attach a heavy duty ratchet strap to the chassis on one side of the vehicle, and to the axle housing on the other side.
- Slowly tighten the strap in small increments to pull the chassis in alignment with the axle. Take measurements after each adjustment until centered.

Pushing Vehicle Body

Although this method will laterally shift position of chassis relative to axle housing, it does not enable the position to be easily stabilized while measurements are taken.

- With the vehicle safely on the ground, have a partner gently push on the vehicle body above the rear wheels.

6. SET ADJUSTABLE TRACKBAR LENGTH AND MOUNT TO AXLE

- With the axle housing centered beneath the chassis, adjust the length of Adjustable Trackbar by rotating the Axle End (A) until the Bushing Sleeve (D) aligns with the mounting holes on the axle bracket.
- Apply anti-seize lubricant to original mounting bolt threads and adjustment threads of trackbar.
- Install Axle End (A) of Adjustable Trackbar to the axle bracket by securing with the original mounting hardware.

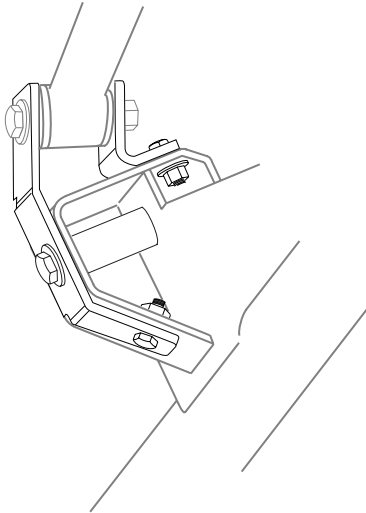

HINT: If Axle End (A) of Adjustable Trackbar does not align with mounting holes in axle bracket, first confirm that the slight bend in Axle End (A) of Adjustable Trackbar is pointing towards the front of vehicle.

If Bushing Sleeve is still out of alignment, it may be necessary to slightly bend the Axle End of track bar using a hydraulic press. Variations in the axle bracket position are typically the result of modifications to related suspension parts.

7. POST-INSTALLATION

- Take measurements again to ensure axle housing is perfectly centered and make any final adjustments if necessary.
- Once all adjustments are complete, fully tighten the Jam Nut (C) to prevent Adjustable Trackbar length from changing. **HINT:** It may be easier to tighten Jam Nut with the Adjustable Trackbar removed from the vehicle.
- Using a torque wrench, tighten mounting hardware at both ends of track bar to 74 ft-lbs.

Maintenance

Check torque specifications regularly.

Regular cleaning with pressurized water is recommended to maximize reliability.

The original equipment trackbar uses the same bushing size as the JKS Adjustable Trackbar. Upon removal of the original trackbar, the OE bushings should be retained if in good condition. In the unlikely event that the Adjustable Trackbar bushings wear out, the OE trackbar bushings may be used as replacements.

© 2009 JKS Manufacturing, Inc & Aftermarketing, LLC
Revision Date 8/6/2009