



# INSTALLATION INSTRUCTIONS

## 77-1553 JEEP 2007-11 Wrangler V6-3.8L

NOTE: EO# D-269-37 ONLY APPLIES TO 2007-2010 MODEL YEAR VEHICLES

NOTE: This kit was not designed to fit vehicles with a body lift.

### TOOLS NEEDED:

- Flat Blade Screwdriver
- Ratchet
- Extension
- 15mm socket
- 10mm socket

### PARTS LIST

Description	Qty.	Part #
A Hose Clamp #44	1	08577
B Hose; 2-3/4"ID -3"ID TPRD; Silicone	1	08096
C Hose Clamp #48	2	08601
D Intake Tube	1	27438
E Grommet; 1"OD,1/2"ID,1/2"Thk.	1	08064
F Bracket; "C", Stl., FB/PC	1	26653
G Bolt; 6mm-1.00 X 16mm, SS	3	07812
H Washer; 1/4" Lock, ZN	1	08198
I Washer; 6mm Flat, SS	7	08269
J Heat Shield	1	07645
K Edge Trim	1	102494
L Bracket; "L", Fin.	1	070712
M Nut; 6mm Nylock, Hexhead, SS	4	07512
N Bracket; Short, FB/PC, Fin.	1	07097
O Stud; M6-1.00 M/M, Rubber Mntd.	1	07027
P Bracket; Sm "L", Mild Stl, FB/PC	1	07195
Q Air Filter	1	RU-4730
R Hose Clamp #10 Mini	1	08411

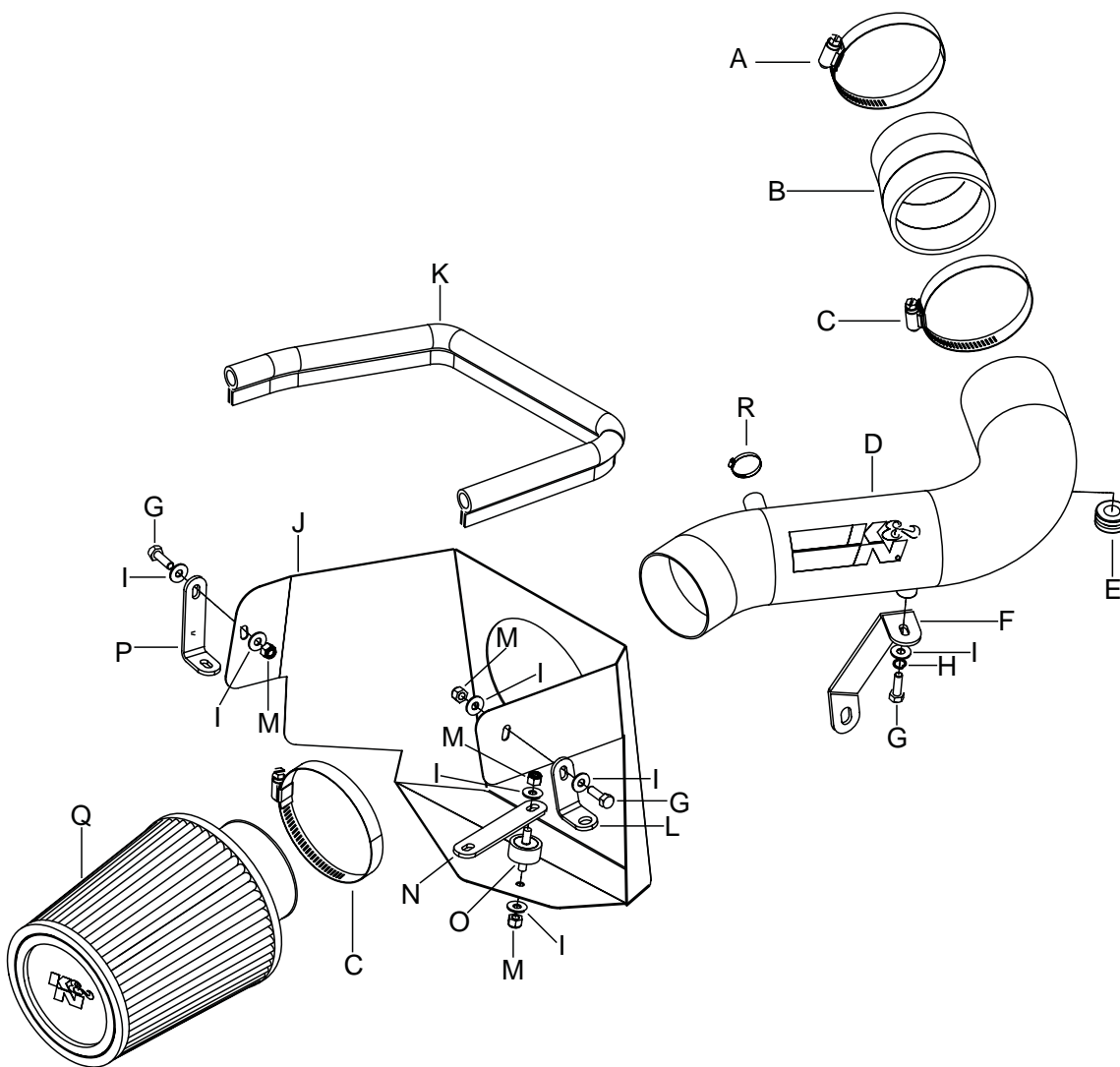

**NOTE: FAILURE TO FOLLOW INSTALLATION INSTRUCTIONS AND NOT USING THE PROVIDED HARDWARE MAY DAMAGE THE INTAKE TUBE, THROTTLE BODY AND ENGINE.**

### TO START:

1. Turn off the ignition and disconnect the negative battery cable.

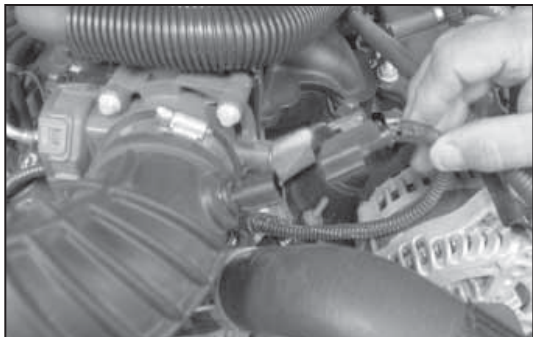

2. Release the locking tab on the air temperature sensor electrical connector and then disconnect the connection.

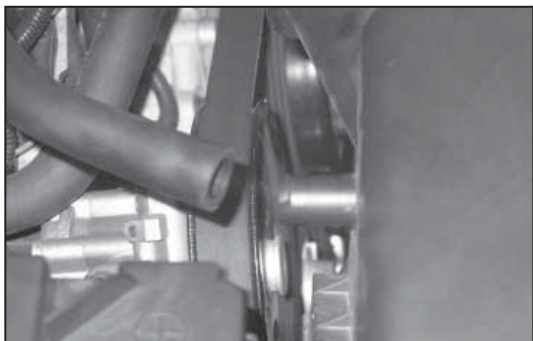

3. Disconnect the crankcase vent hose from the stock intake tube as shown.



4. Loosen the hose clamp that secures the stock intake tube to the throttle body and then disconnect the intake tube from the throttle body.

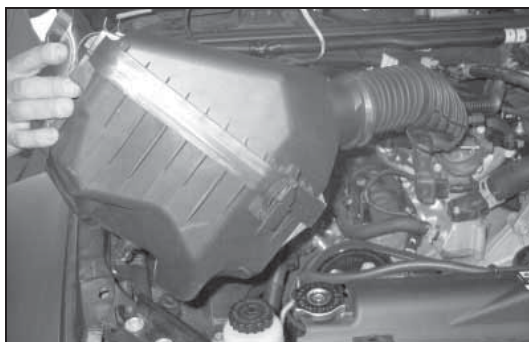

5. Lift up the airbox assembly to dislodge it from the mounting grommets and remove the complete assembly from the vehicle.

**NOTE: K&N Engineering, Inc., recommends that you do not discard your factory air intake.**



6. Install the supplied grommet into the hole in the K&N intake tube as shown.

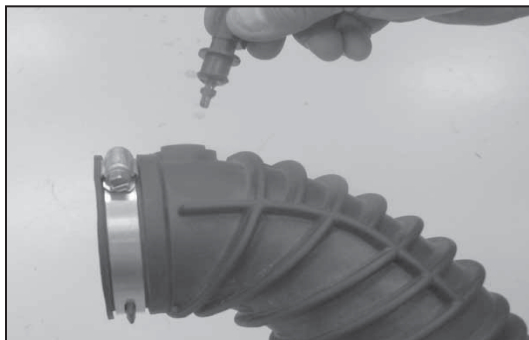

7. Remove the air temperature sensor from the stock intake tube as shown.

**NOTE: Take care when handling the air temperature sensor as it is very fragile.**



8. Install the air temperature sensor into the grommet installed into the K&N intake tube during step #6.

**NOTE: Take care when handling the air temperature sensor as it is very fragile.**

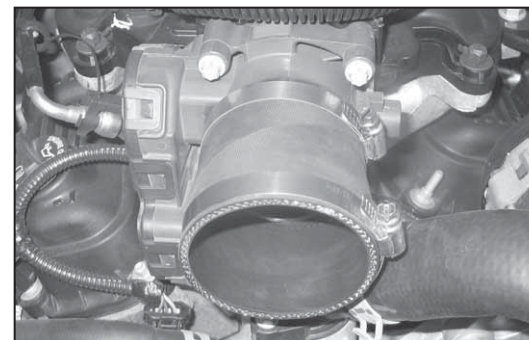

9. Install the supplied silicone hose (08096) onto the throttle body and secure with the supplied hose clamp.

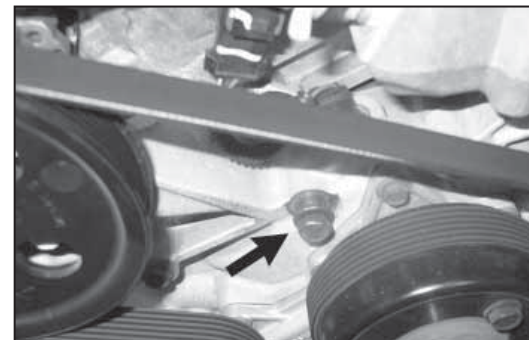

10. Remove the front engine bolt shown. **NOTE: This bolt will be reused.**

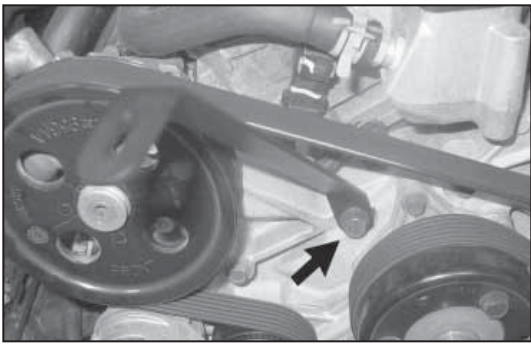

11. Install the supplied tube mounting bracket (26653) onto the engine and secure with the bolt removed in step #10.

**NOTE: Be sure the bracket sits flush to the engine.**

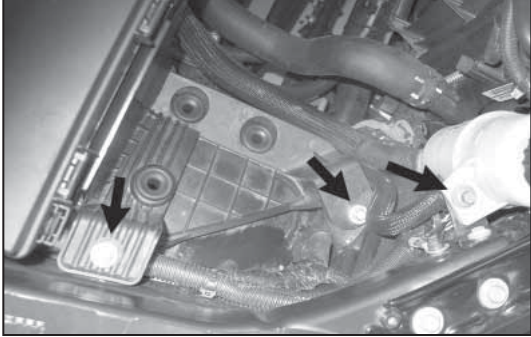

12. Remove the power steering reservoir mounting bolt and the two airbox bracket mounting bolts shown.

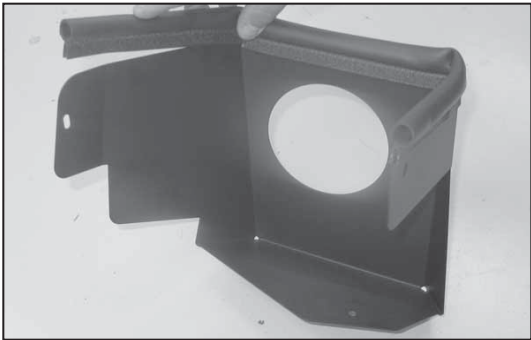

13. Install the supplied edge trim onto the heat shield as shown.

**NOTE: Some trimming of the edge trim may be necessary.**

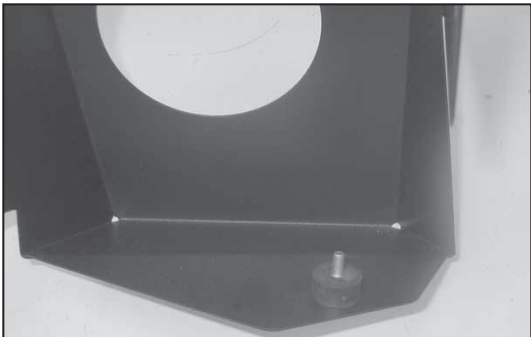

14. Install the supplied rubber mounted stud onto the heat shield with the provided hardware as shown.



15. Install the supplied bracket (07097) onto the rubber mounted stud as shown.

**NOTE: Do not completely tighten at this time.**

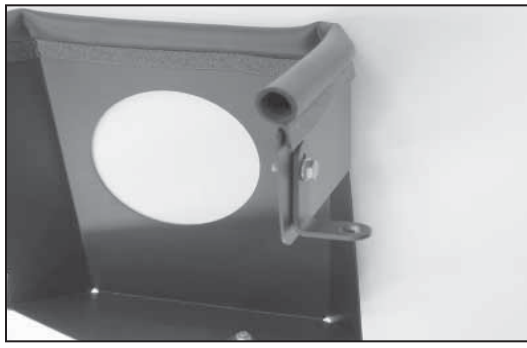

16. Install the supplied "L" bracket (070712) onto the heat shield as shown with the provided hardware.

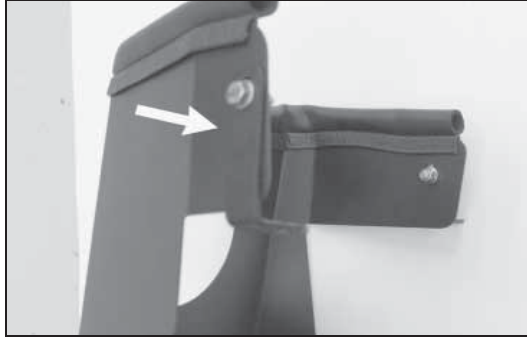

17. Install the supplied "L" bracket (07195) onto the heat shield as shown with the provided hardware.

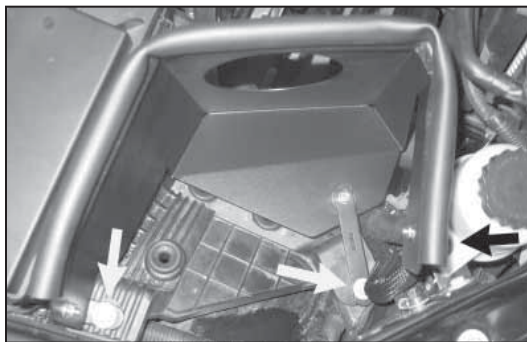

18. Install the heat shield assembly into the engine compartment and secure with the three bolts removed in step #12.



19. Insert the K&N® intake tube into the silicone hose at the throttle body and align with the mounting bracket installed in step #11 and then secure with the hose clamp and hardware provided.



20. Connect the crankcase vent hose to the K&N® intake tube and secure with the provided hose clamp as shown.

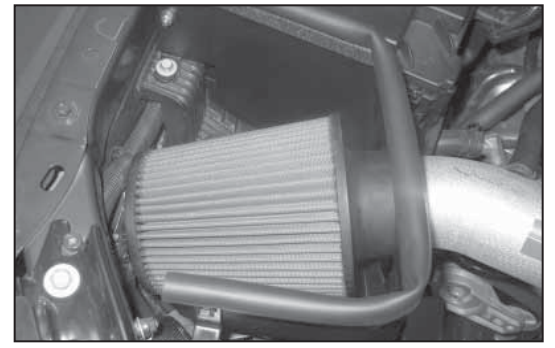

21. Install the K&N® air filter and secure with the provided hose clamp.

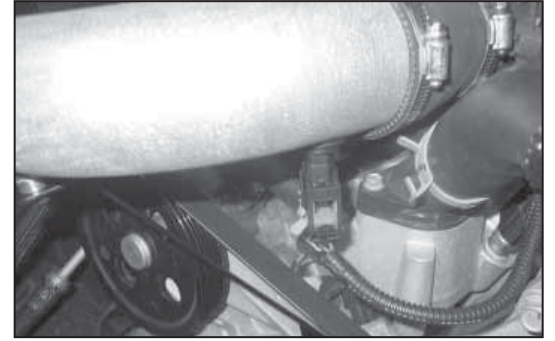

22. Reconnect the air temperature sensor electrical connection.



23. Reconnect the vehicle's negative battery cable. Double check to make sure everything is tight and properly positioned before starting the vehicle.

24. The C.A.R.B. exemption sticker, (attached), must be visible under the hood so that an emissions inspector can see it when the vehicle is required to be tested for emissions. California requires testing every two years, other states may vary.

25. It will be necessary for all K&N® high flow intake systems to be checked periodically for realignment, clearance and tightening of all connections. Failure to follow the above instructions or proper maintenance may void warranty.

#### ROAD TESTING:

1. Start the engine with the transmission in neutral or park, and the parking brake engaged. Listen for air leaks or odd noises. For air leaks secure hoses and connections. For odd noises, find cause and repair before proceeding. This kit will function identically to the factory system except for being louder and much more responsive.

2. Test drive the vehicle. Listen for odd noises or rattles and fix as necessary.

3. If road test is fine, you can now enjoy the added power and performance from your kit.

4. K&N Engineering, Inc., suggests checking the air filter element periodically for excessive dirt build-up. When the element becomes covered in dirt (or once a year), service it according to the instructions on the Recharger® service kit, part number 99-5050 or 99-5000.

**STREET LEGAL IN MOST STATES**

**NOT LEGAL FOR USE IN CA & OTHER STATES  
ADOPTING CA EMISSIONS STANDARDS**

See our catalog or [knfilters.com](http://knfilters.com) for CARB status on each part for a specific vehicle

\* FREE K&N® decal To register your warranty, please see us online at [knfilters.com/register](http://knfilters.com/register). FREE K&N® decal \*

• 1455 CITRUS ST., P.O. BOX 1329, RIVERSIDE, CA., U.S.A. 92502 • TECH SERVICE 800-858-3333 • FAX 951-826-4001  
• e-mail: [tech@knfilters.com](mailto:tech@knfilters.com) • WWW: <http://www.knfilters.com>

18851J  
08/01/11