

JK Wrangler Modular XHD Aluminum Front Bumper

Contents:

1. Bumper Center Section (1)
2. D-Ring (2)
3. Top Cover plate (1)
4. M12 x 60 Bolt (8)
5. M12 Washer (8)
6. M12 Lock Nut plate (4)
7. Plastic plugs (6)
8. Rubber Isolator Gasket (2)
9. M8 Countersunk Screw (4)
10. M8 Flat Washer (4)
11. M8 Hex Nut (4)

Optional Accessories shown: (Not included)

- Hoop Over rider (11541.14)
- Stubby Ends (11540.10)
- Winch Plate (11541.13)

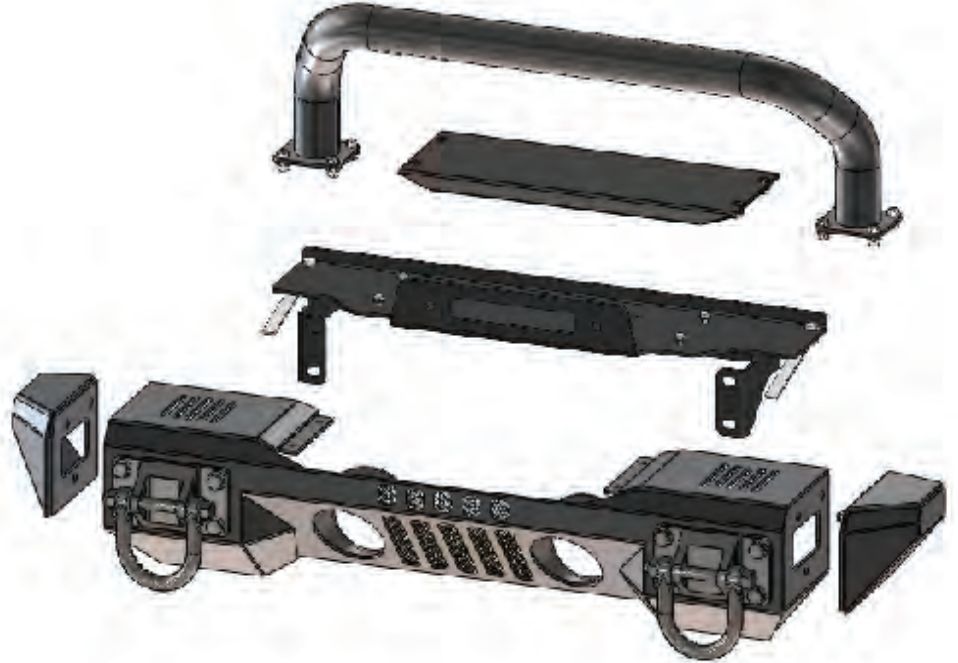

Note: When purchasing optional accessories, refer the accessory instructions first before installation of the bumper center section. The bumper will need to be removed for some accessories.

1. Remove the factory front bumper. First disconnect the fog lights by twisting the plug in the rear of the light housings. Next remove the factory air dam. Remove the 4 nuts per frame horn that hold the original front bumper to the vehicle.
2. Remove the factory fog lights from the bumper. Do not discard the screws as they will be re-used.
3. Install the original fog lights into the Center Section from the back. Use the factory screws to secure the fog lights into the new bumper.

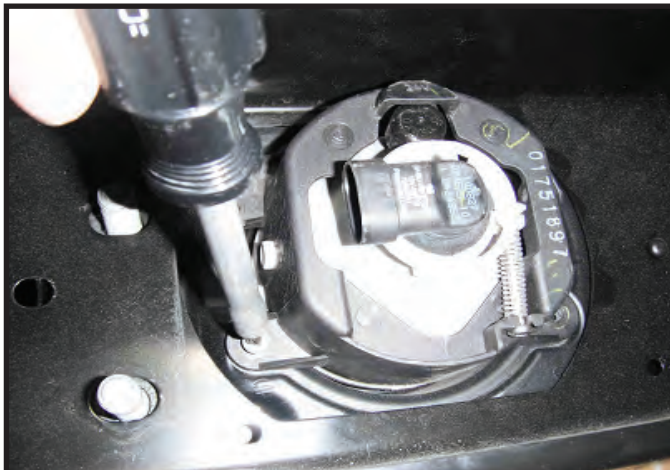

4. Place Center Section of Bumper onto the frame rails. Align the holes and place the rubber isolator gasket between the bumper and D-rings. Using the supplied M12 bolts, place a washer on each of the bolts and insert them thru the D-rings and into the bumper. Note: The D-ring bolt holes are wider on the top.



5. Install the L-bracket nut plates on the back side of the bumper with the L portion on the bottom. Tighten both top and bottom bolts in small increments evenly on each nut plate.
6. Reconnect the fog lights.

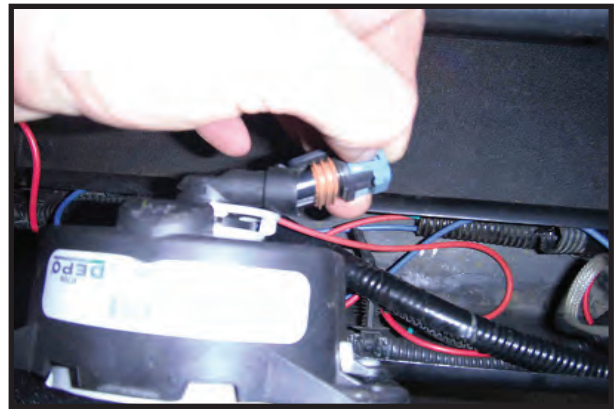

7. Install the top cover plate using the (4) pan head screws with a nut and washer on the bottom of each.
8. Install the (6) plastic filler plugs in each of the three holes on each side of the bumper.



For Technical Assistance Contact:
OMIX-ADA Tech Support
Phone: 1-800-449-6649
Email: techsupport@omix-ada.com
Web: www.Omix-Ada.com

© Copyright Omix-Ada 2011