



















Installation Instructions Trektop™

Vehicle Application

- Jeep Wrangler (JK)
2007 – Current
Part Number: 56804

www.Bestop.com - We're here to help! Visit our web site and click on ["Ask a Question"](#). Click here for more [Jeep Accessories by Bestop.](#)

<p>INSTALLATION TIME</p>  <p>1 Hour</p>	<p>SKILL LEVEL</p> <p>1 2 3 4</p> <p>2 - Moderately Easy</p>								
<p>TOOLS</p> <table border="0"> <tr> <td data-bbox="226 732 359 862">  Phillips Screwdriver #2 </td> <td data-bbox="390 732 541 862">  Wrench 3/8" and 7/16" </td> <td data-bbox="562 732 688 829">  50/50 Solution Alcohol/Water </td> <td data-bbox="730 732 863 829">  Scissors </td> </tr> <tr> <td colspan="4" data-bbox="226 886 348 984">  Safety Glasses </td> </tr> </table>		 Phillips Screwdriver #2	 Wrench 3/8" and 7/16"	 50/50 Solution Alcohol/Water	 Scissors	 Safety Glasses			
 Phillips Screwdriver #2	 Wrench 3/8" and 7/16"	 50/50 Solution Alcohol/Water	 Scissors						
 Safety Glasses									



 **CAUTION** Safety glasses should be worn at all times while installing this product.

Installation Tips
 Before you begin installing this assembly, read all instructions thoroughly.

For a smooth fit:
 For ease in installation, the product should be installed at temperatures above 72° F. Below this temperature, the fabric may contract an inch or more, making it difficult to fit to the vehicle. It is normal for fabric to contract and wrinkle when stored in the shipping carton. Within a few days after the installation, the fabric will relax and the wrinkles will disappear.

 **WARNING** This product is designed primarily to enhance the appearance of the vehicle and to shield the occupants from ordinary weather conditions. Do not rely in any way on the components of this product to contain occupants within the vehicle, or to protect against injury or death in the event of an accident. This product will not protect the occupants from falling objects. Never operate the vehicle in excess of manufacturer's specifications.

WEAR SEAT BELTS AT ALL TIMES

Read and follow, precisely, all installation instructions provided when installing product. Failure to do so may result in a poor fit and could place occupants of the vehicle in a potentially dangerous situation.

Trektop™ – Installation Instructions

Parts List and Hardware Identification

Top Fabric Rear Window	Qty - 1 Qty - 1
---------------------------	--------------------



48-1/2" Bow Qty - 1,
Part Number 459.23

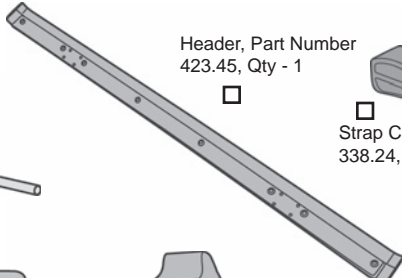

Header, Part Number
423.45, Qty - 1

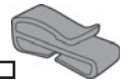

Strap Clip, Part Number
338.24, Qty - 1



End Cap, Part
Number 401.56,
Qty - 2



Header Knob Plate, Part
Number 445.10, Qty - 2

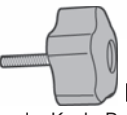

Header Knob, Part
Number 440.55, Qty - 2

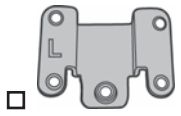

Header Knob Base -
Left, Part Number
445.09, Qty - 1

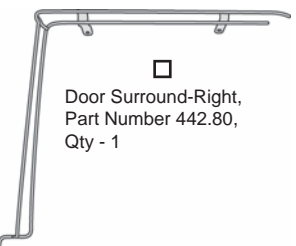

Door Surround-Right,
Part Number 442.80,
Qty - 1

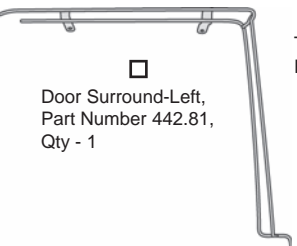



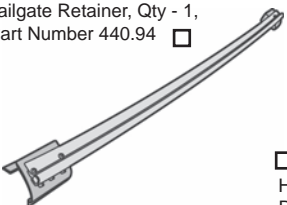

Door Surround-Left,
Part Number 442.81,
Qty - 1

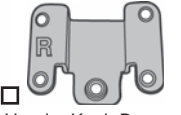

Tailgate Retainer, Qty - 1,
Part Number 440.94

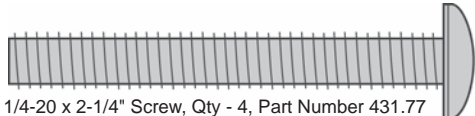
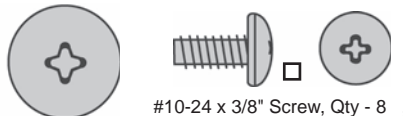

Header Knob Base -
Right, Part Number
445.08, Qty - 1

	
1/4-20 x 2-1/4" Screw, Qty - 4, Part Number 431.77	#10-24 x 3/8" Screw, Qty - 8 , Part Number 195.92
	
1/4-20 Hex Nut, Qty - 4, Part Number 436.17	1/4" Flat Washer, Qty - 4, Part Number 257.93
	
1/4" Lock Washer, Qty - 4, Part Number 397.21	#10-24 Silver Lock Nut" data-bbox="385 735 435 800"/>
	#10-24 Silver Lock Nut, Qty - 8, Part Number 195.93

1 Install Door Surrounds

Install the pin of the Door Surround into the hole on the top of the body behind the door opening.

Place the upper brackets of the Door Surround over the holes on top of sport bar. Secure the surround with 1/4-20 x 2-1/4" Screws, 1/4" Flat Washers, 1/4" Lock Washers and 1/4-20 Hex Nuts.

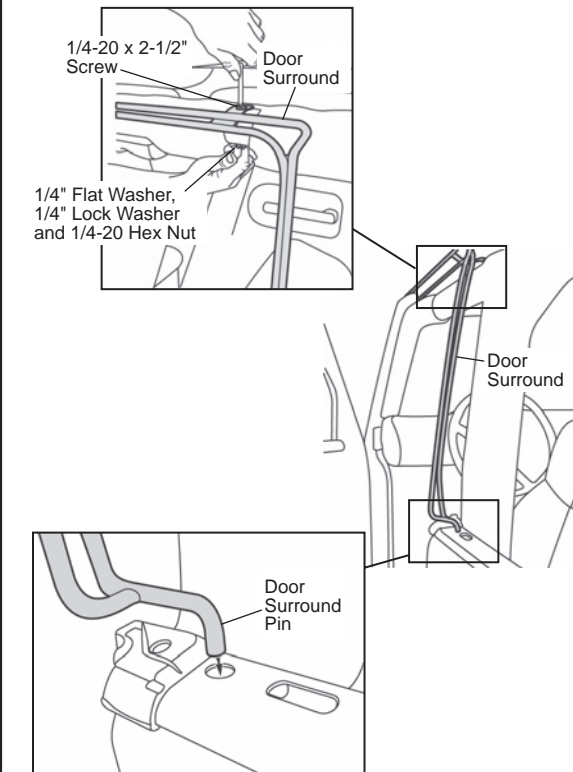

Trektop™ – Installation Instructions

2 Install Header Knob Bases on Header

The bottom of each Header Knob Base is stamped with an R for right or an L for left.

Place the Right Header Knob Base over the four holes with the tab of the base pointing to the front of the Header. Secure the Header Knob Base to the Header with four (4) #10-24 x 3/8" Phillips Truss Head Screws and four (4) #10-24 Locknuts.

Repeat this procedure with the left base.



CAUTION

The Header will not seal if the Header Knob Bases are not installed correctly.

installed correctly.

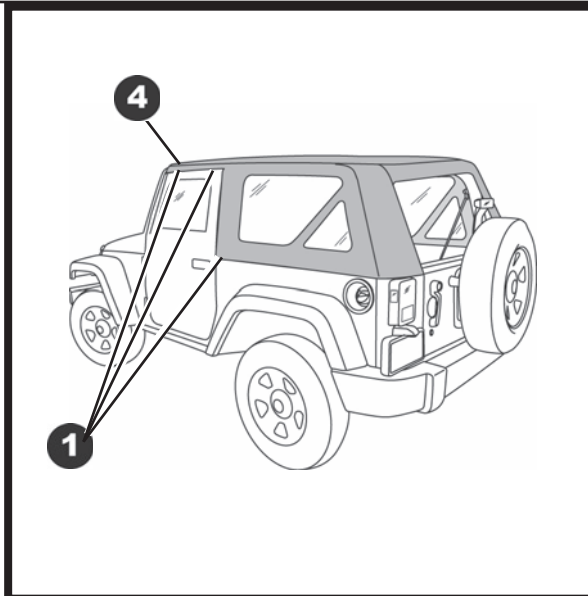
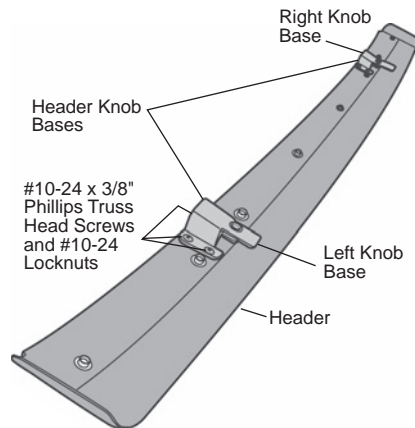

3 Snap Trektop™ to Header

Slide the pocket sewn along the front of the Trektop™ over the edge of the header and snap it to the snaps.

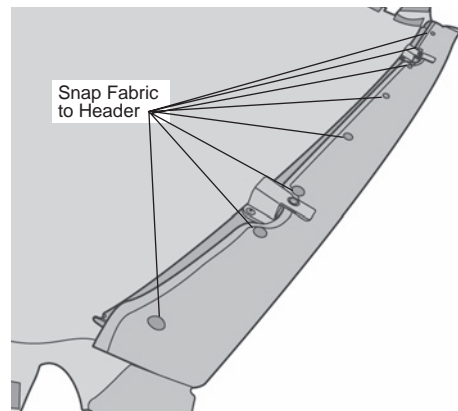

4 Secure Header to Windshield

Center the Trektop™ on the vehicle. Place the tabs on the Header Knob Bases above the footman loops in the windshield frame. Place a Header Knob Plate under a footman loop. Install a Header Knob through the plate and footman loop and thread it into the Header Knob Base. Repeat this with both Header Knob Bases.

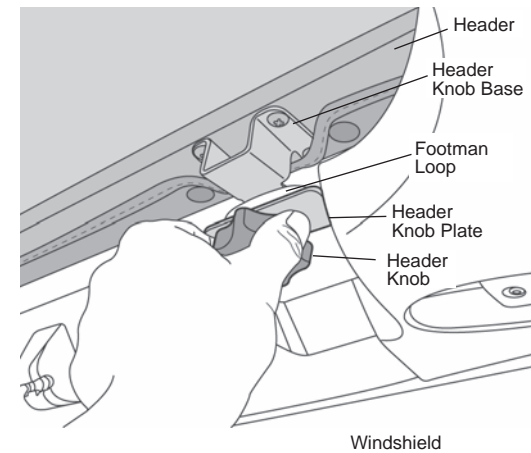

Trektop™ – Installation Instructions

5 Drape Top Fabric over vehicle

Drape the top fabric over the speaker pod and sport bar. Pull the quarter windows over the sides of the sport bar.

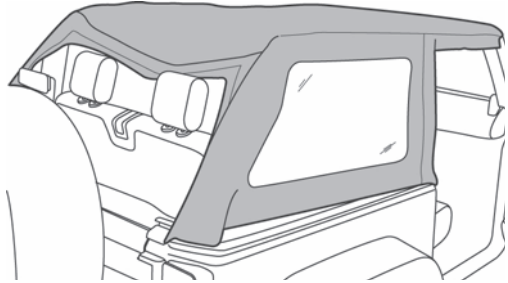

6 Install Bow

Push an End Cap into each end of the Bow. Slide one end of the Bow into one of the pockets in the rear of the top fabric. Slip the other end into the other pocket and center the Bow on top of the sport bar.

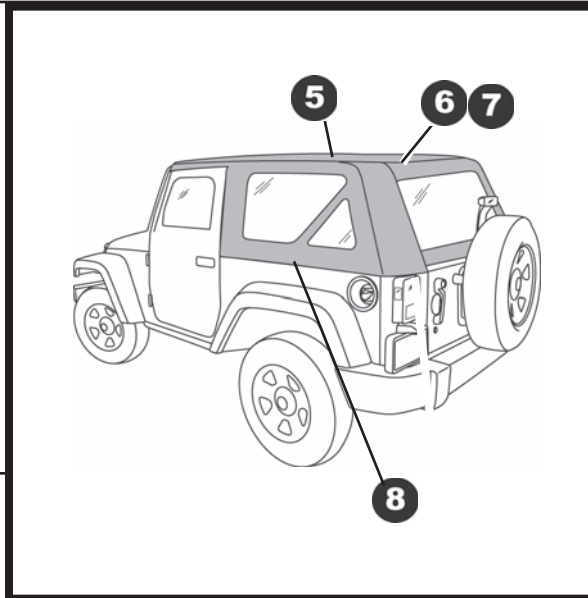
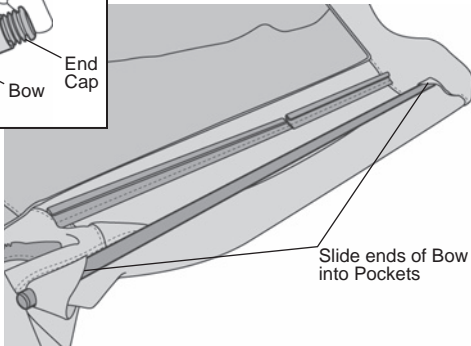
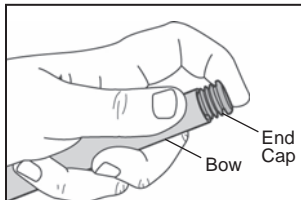

7 Install Rear Window

Orient the Rear Window with the plastic J-Hook toward the top. Align the J-Hook on the top of the window with the J-Hook sewn into the top above the rear window opening. Slide them together until the rear window is centered in the opening. Engage the zippers on each side of the window, but do not close them yet.

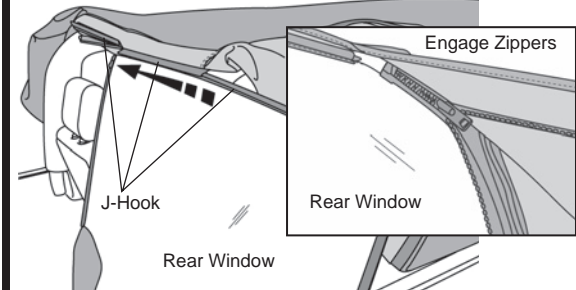

8 Secure Quarter Windows

Start from the front and slip plastic retainer strips along the bottom of the quarter windows into the channel on the vehicle.

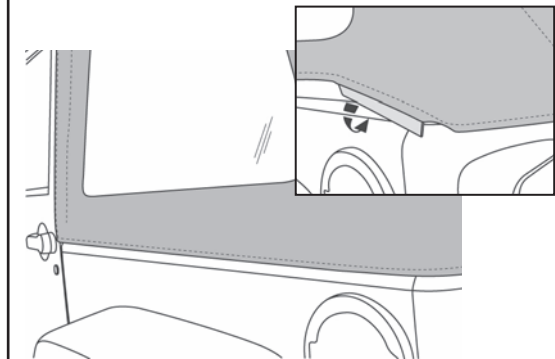

Trektop™ – Installation Instructions

9 Install Tailgate Retainer on Rear Window

Remove the Rear Window from the box and lay it flat with the backing side up. Locate the Tailgate Retainer. The bar has a “C” shaped channel, when viewed from the end. Orient the retainer with the round seal down and slide the “C” channel on the retainer onto the tubed strip sewn to the backing side of the Rear Window.

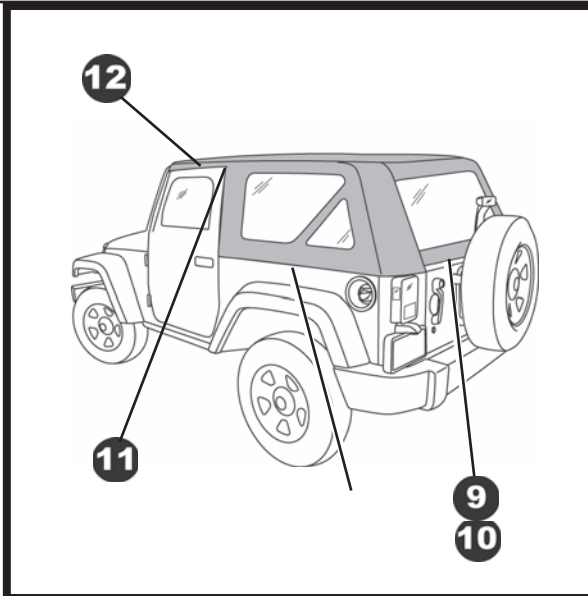
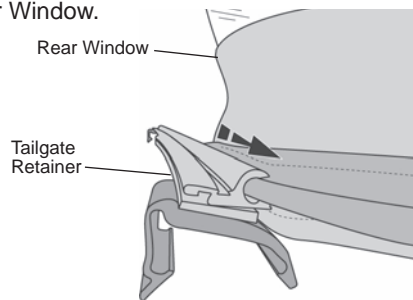

12 Secure Center Deck Strap

Wrap the flap around the Door Surround and tuck it between the surround and the sport bar on each side of the vehicle. Pull the strap across the vehicle and thread it through the buckle on the opposite side. Pull it tight and install a Strap Clip to secure the end of the strap.

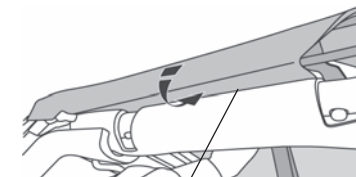

Wrap Flap around Door Surround and Tuck between Surround and Sport Bar

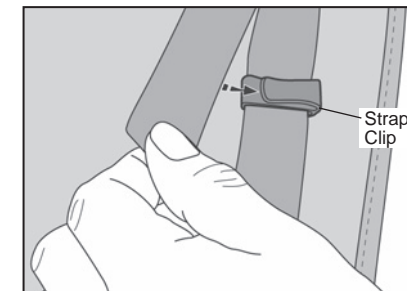
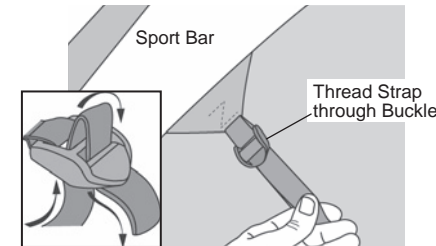

10 Install Tailgate Retainer on Vehicle

Hook the bottom of each clip on the bottom of the Tailgate Retainer under the rear edge of the belt rail. Roll the retainer toward the inside of the vehicle until it clips into place.

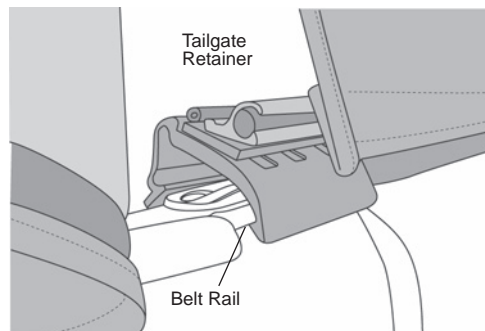

11 Secure the Quarter Window

Wrap the fabric flap on the front of the quarter window around the Door Surround and fasten the hook and loop to each other.

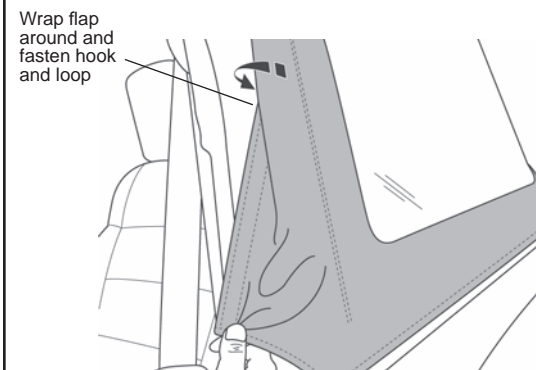

Trektop™ – Installation Instructions

13 Secure Small Door Flaps

Wrap the two small flaps around the front and rear of the Door Surround. Fasten the hook and loop strips to each other.

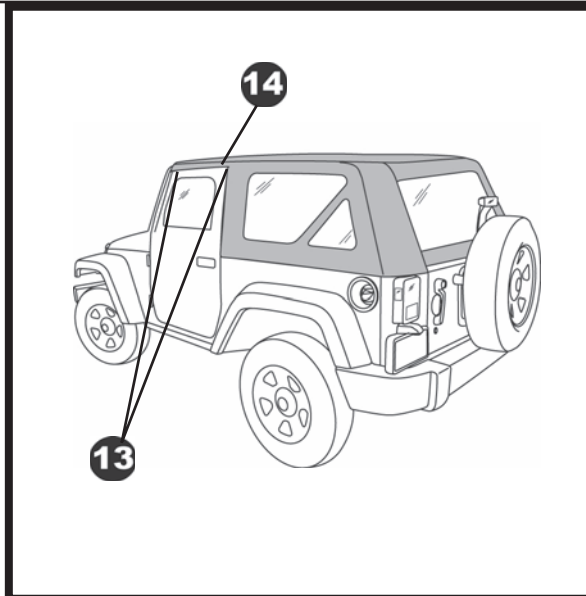
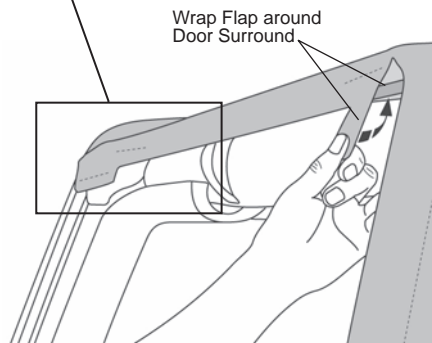
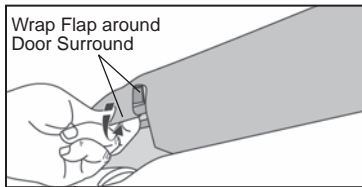

14 Adjusting the Top for Open Air Driving

The Top fabric may be rolled back to expose the front seats. Roll the fabric to the desired position. Wrap the strap around the Door Surround and snap it to itself on each side of the vehicle.

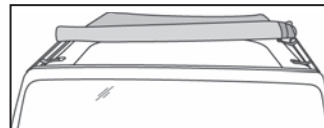

Wrap Strap around Door Surround and snap to itself

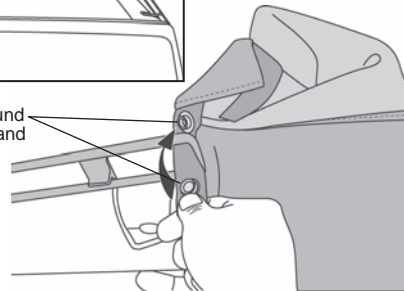

Trektop™ – Installation Instructions

Care and Maintenance of your Bestop Product

Your Bestop product is made of the finest materials available. To keep it looking new and for the maximum possible wear, it will need periodic cleaning and maintenance.

Washing: The fabric should be washed often using soap, warm water and a soft bristle brush. Rinse with clear water to remove all traces of soap or use Bestop-recommended Bestop Cleaner and Bestop Protectant. Bestop Cleaner and Bestop Protectant are specially formulated to provide a total cleaning and protection system. Bestop Cleaner will not harm vehicle finish, is biodegradable and environmentally friendly. Bestop Protectant protects against UV-fading, cracking and hardening.

Windows: Keep windows clean to avoid scratching. DO NOT use a brush on the windows! Wash with a water-soaked cloth or sponge and a mild dishwashing detergent or use Bestop-recommended Bestop Vinyl Window Cleaner, which safely cleans and protects vinyl windows while helping prevent UV damage. NEVER WIPE THE WINDOWS WHEN THEY ARE DRY. Be careful when cleaning snow or frost from the vinyl windows since they are easily scratched and may crack at low temperatures. DO NOT roll the sides or rear window in cold weather. The windows become stiff and will crack.

Zippers: Keeping the zipper cleaned and lubricated with a silicone lubricant will help prevent damage and keep the zippers in a smooth working condition. If a zipper opens behind the slider, the slider may have been spread apart. This problem can usually be repaired by using an ordinary pair of pliers to bring the sides back into parallel. Return slider to the end of the zipper in the normal Open position. Squeeze lightly at first and test the zipper. If the zipper continues to remain open squeeze more firmly with the pliers and try the zipper again. Repeat this procedure until the zipper operates correctly.

Water: Seeping through at the seams may be stopped by applying 3-M Scotchgard® on the inside of the seams. Rips in the fabric may be repaired with Bondex® iron on patches. Iron the patches to the Inside of the top, carefully following the Bondex® instructions.

Snaps: Keep snaps cleaned and lubricated with silicone to help prevent snaps from sticking to the studs. If a snap does become stuck to a stud, use a screwdriver and GENTLY pry apart to prevent permanent damage to the snap or the top fabric.

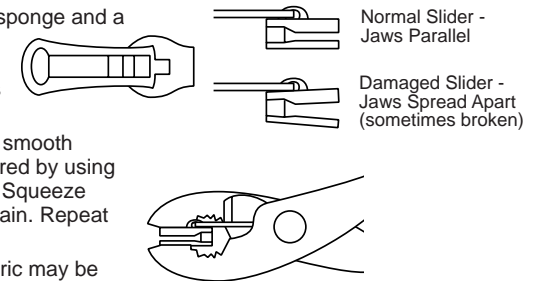

LIMITED WARRANTY

We warrant our product to be free from defects in material and workmanship, for the terms specified below, provided there has been normal use and proper maintenance. This warranty applies to the original purchaser only. All remedies under this warranty are limited to the repair or replacement of any item or items found by the factory to be defective within the time period specified. If you have a warranty claim, first you must call our factory at the number below for instructions. You must retain proof of purchase and submit a copy with any items returned for warranty work. Upon completion of warranty work, if any, we will return the repaired or replaced item or items to you freight prepaid. Damage to our products caused by accidents, fire, vandalism, negligence, misinstallation, misuse, Acts of God, or by defective parts not manufactured by us, is not covered under this warranty.

THE WARRANTY TIME PERIOD IS AS FOLLOWS FOR REPLACE-A-TOP™, SAILCLOTH REPLACE-A-TOP™, SUPERTOP®, SUPERTOP® REPLACEMENT SKINS, SUNRIDER®, AND TIGERTOP®: TWO YEARS FROM DATE OF PURCHASE.

THE WARRANTY TIME PERIOD IS AS FOLLOWS FOR ALL OTHER "SOFT GOODS" MANUFACTURED BY OUR COMPANY (USING PRIMARILY VINYL, PLASTICS, AND/OR FOAM): ONE YEAR FROM DATE OF PURCHASE.

THE WARRANTY TIME PERIOD IS AS FOLLOWS FOR ALL OTHER "HARD GOODS" MANUFACTURED BY OUR COMPANY (USING PRIMARILY METALS, PLASTICS, AND/OR FIBERGLASS): ONE YEAR FROM DATE OF PURCHASE.

ANY IMPLIED WARRANTIES OF MERCHANTABILITY AND/OR FITNESS FOR A PARTICULAR PURPOSE CREATED HEREBY ARE LIMITED IN DURATION TO THE SAME DURATION AND SCOPE AS THE EXPRESS WRITTEN WARRANTY. OUR COMPANY SHALL NOT BE LIABLE FOR ANY INCIDENTAL OR CONSEQUENTIAL DAMAGE.

Some states do not allow limitations on how long an implied warranty lasts, or the exclusion or limitation of incidental or consequential damages, so the above limitations or exclusions may not apply to you. This warranty gives you specific legal rights, and you may also have other rights which vary from state to state.

For further information or request for warranty work, please contact:

Bestop Inc., Customer Service
Toll-Free: (800)845-3567
Main: (303)465-1755
E-mail: csbestop@Bestop.com
Website: www.Bestop.com

