

# **INSTALLATION INSTRUCTIONS**

**PNC SIDEBAR  
2018 WRANGLER JL 2DR**

**Parts List:**

1	Driver/left side PNC Sidebar	4	10-1.5mm x 30mm Hex Bolts
1	Passenger/right side PNC Sidebar	8	10mm x 24mm x 2mm Flat Washers
1	Driver/left side Front Mounting Bracket	4	10-1.5mm Nylon Lock Nuts
1	Passenger/right side Front Mounting Bracket	8	8-1.25mm Combo Bolts
1	Driver/right side Rear Mounting Bracket	4	8-1.25mm x 35mm Hex Bolts
1	Passenger/right side Rear Bracket	4	8mm x 28mm x 3mm Flat Washers
1	Driver/left side Front Support Bracket	4	8mm Lock Washers
1	Passenger/right side Front Support Bracket	8	6-1.0mm x 25mm Hex Bolts
1	Driver/left side Rear Support Bracket	16	6mm x 22mm x 2mm Flat Washers
1	Passenger/right side Rear Support Bracket	8	6-1.0mm Nylon Lock Nuts

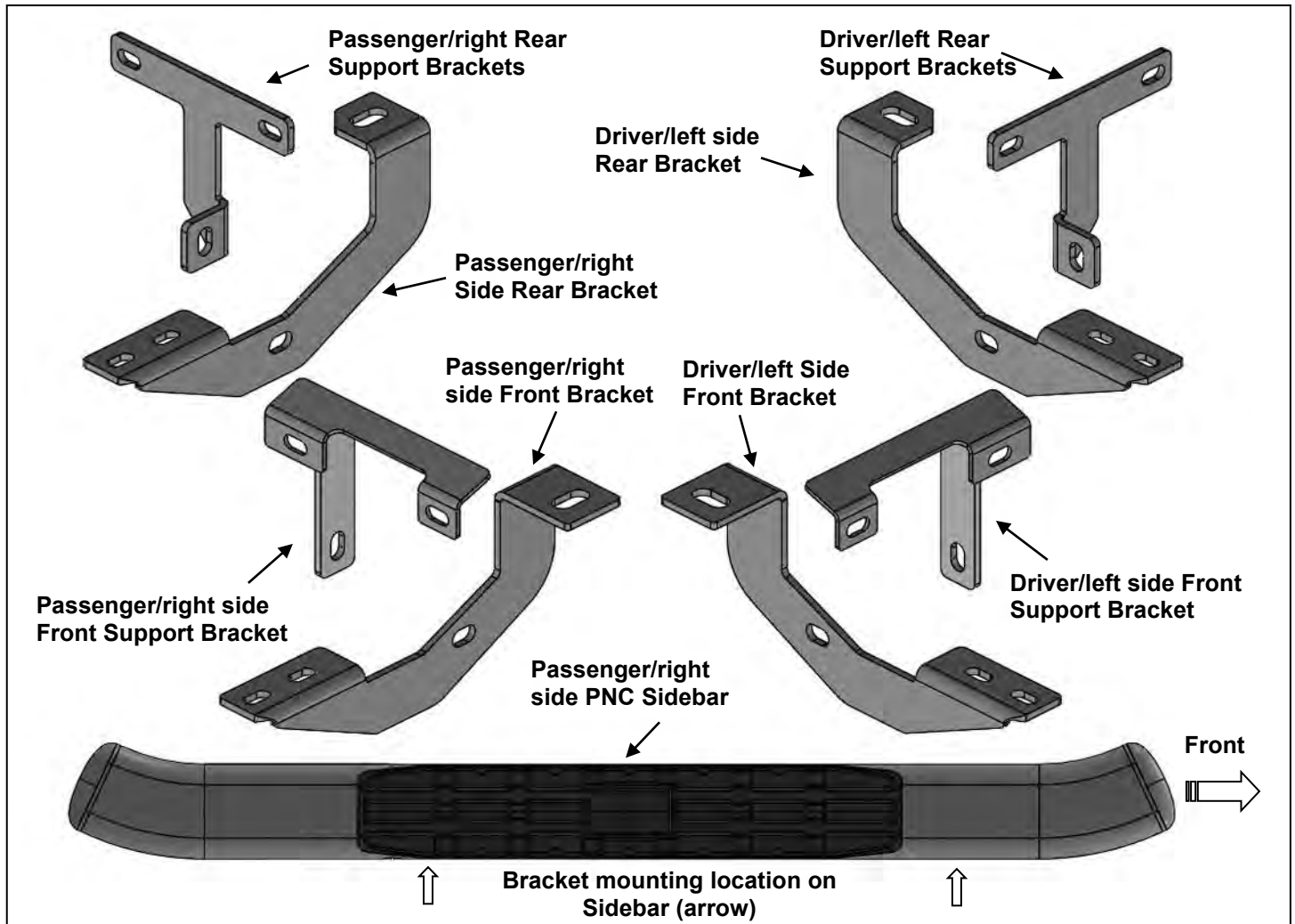

**PROCEDURE:**

**REMOVE CONTENTS FROM BOX. VERIFY ALL PARTS ARE PRESENT. READ INSTRUCTIONS CAREFULLY BEFORE STARTING INSTALLATION. FACTORY INSTALLED OR AFTERMARKET "ROCK RAILS," SIDE STEPS OR RUNNING BOARDS MUST BE REMOVED.**

1. Start installation toward the front of the passenger side of the vehicle and find the front threaded insert located in between the first pair of holes along the pinch weld, **(Figure 1)**.
2. Select the Passenger/right side Front Mounting Bracket, **(Figure 2)**. **IMPORTANT:** Use the illustration above to properly identify the Mounting Bracket. Attach the Bracket to the threaded insert using (1) 8mm Hex Bolt, (1) 8mm Lock Washer and (1) 8mm Flat Washer, **(Figure 2)**. Do not tighten hardware at this time.

- Next, select the Passenger/right side Front Support Bracket, **(Figure 3)**. **IMPORTANT:** Use the illustration above to help identify the correct Support and Mounting Bracket. Attach the Support Bracket to the **back** of the pinch weld using (2) 6mm Hex Bolts, (4) 6mm Flat Washers and (2) 6mm Nylon Lock Nuts, **(Figures 3—5)**. **NOTE:** Insert bolts from the outside of the pinch weld and through the Bracket. Use (1) 10mm Hex Bolt, (2) 10mm Flat Washers and (1) 10mm Nylon Lock Nut to secure the Support Bracket to the **rear** side of the Mounting Bracket, **(Figures 4 & 5)**. Do not tighten hardware at this time.
- Move to the rear mounting location and locate the threaded insert and pair of holes on the pinch weld, **(Figure 6)**. Repeat **Steps 3 & 4** to install the Rear Brackets, **(Figure 7)**. Use the illustration above to help determine the correct Rear Brackets.
- Select the Passenger/Right Sidebar. Use the illustration above to help identify the correct Sidebar for each side. Carefully position the Sidebar onto the (3) Mounting Brackets. **IMPORTANT:** Do not slide, (front to back or rotate), the Sidebar on the Brackets or damage to the finish on the Sidebar may result. Attach the Sidebar to the Mounting Brackets with (4) 8mm x 25mm Combination Hex Bolts, **(Figures 8—11)**. Do not tighten hardware. **NOTE:** Mounting cradles on Brackets should be inline and pointing toward the rear of the vehicle for proper installation.
- Level and adjust the Sidebar and tighten all hardware.
- Repeat **Steps 1—6** for driver/left Sidebar installation.
- Do periodic inspections to the installation to make sure that all hardware is secure and tight.

**To protect your investment**, wax this product after installing. Regular waxing is recommended to add a protective layer over the finish. Do not use any type of polish or wax that may contain abrasives that could damage the finish. Mild soap may be used to clean Sidebar.

### Passenger Side Installation Pictured

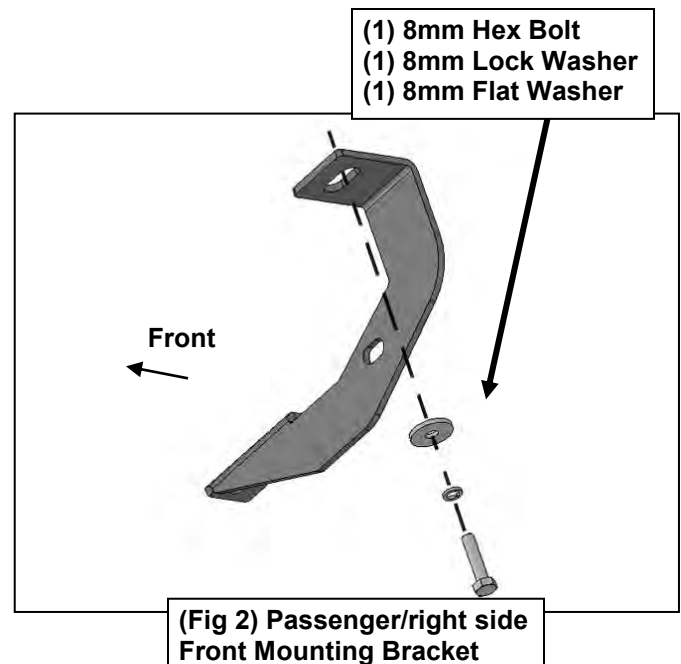
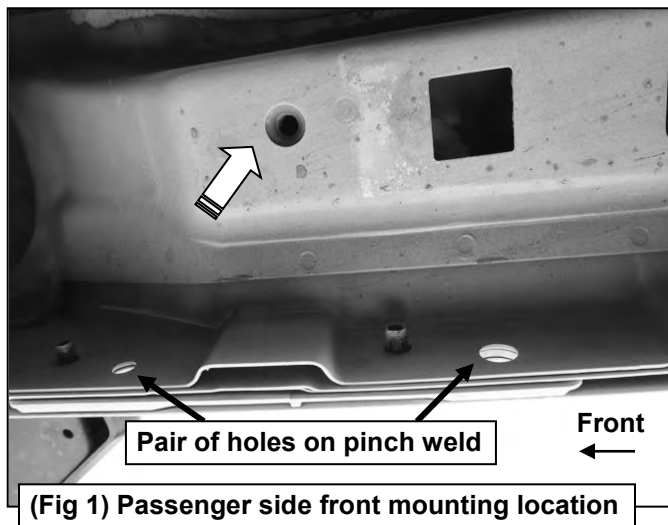

### Passenger Side Installation Pictured

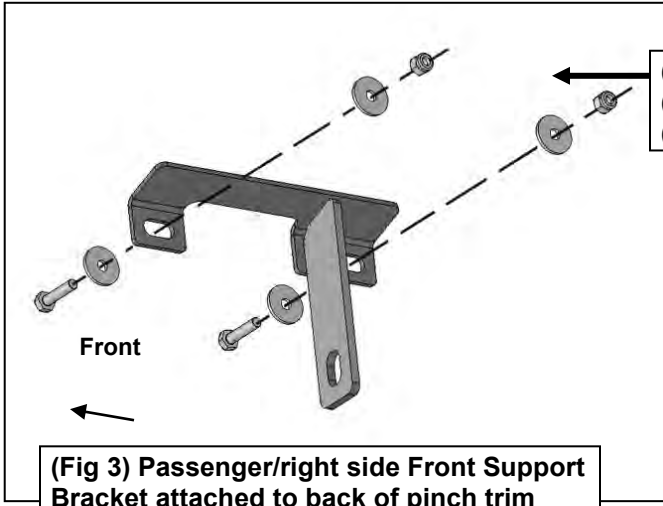

(Fig 3) Passenger/right side Front Support Bracket attached to back of pinch trim

- (2) 6mm Hex Bolts
- (4) 6mm Flat Washers
- (2) 6mm Nylon Lock Nuts

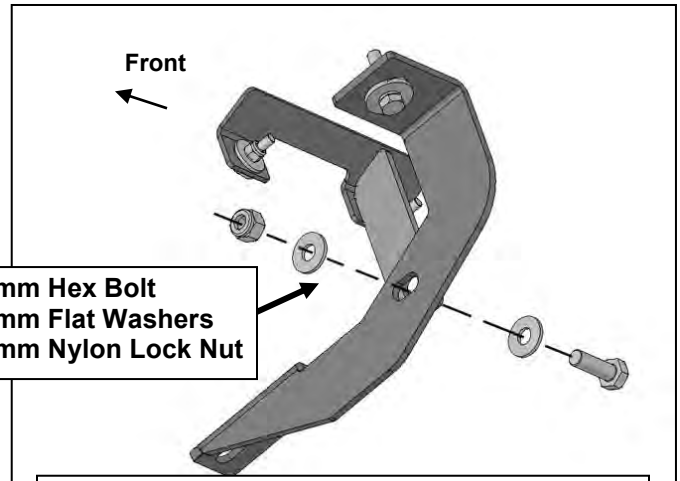

- (1) 10mm Hex Bolt
- (2) 10mm Flat Washers
- (1) 10mm Nylon Lock Nut

(Fig 4) Passenger/right side Front Support Bracket attached to rear side of Front Bracket

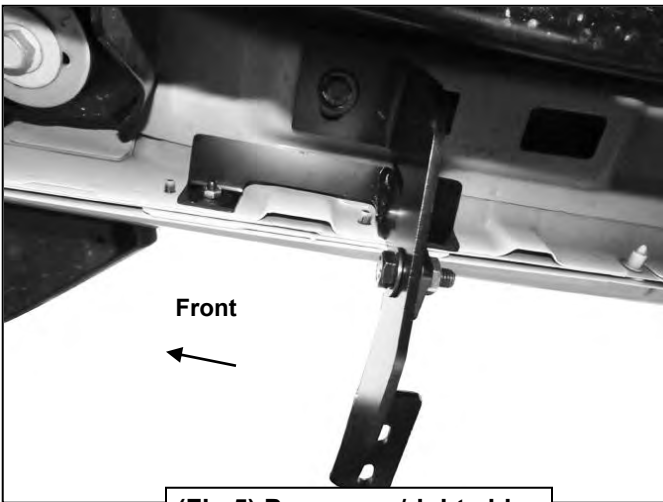

(Fig 5) Passenger/right side Front Brackets installed

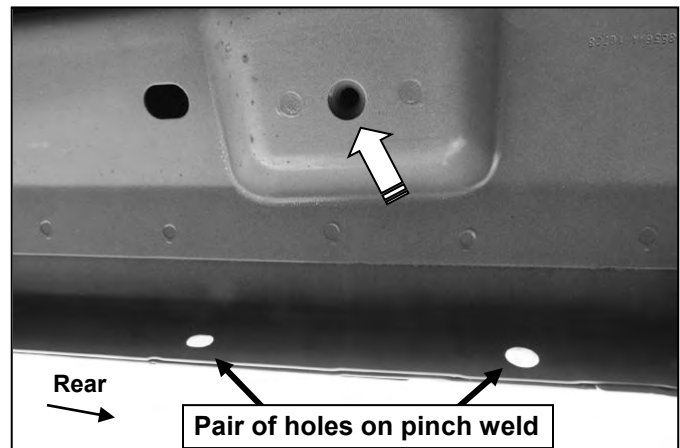

(Fig 6) Passenger side rear mounting location

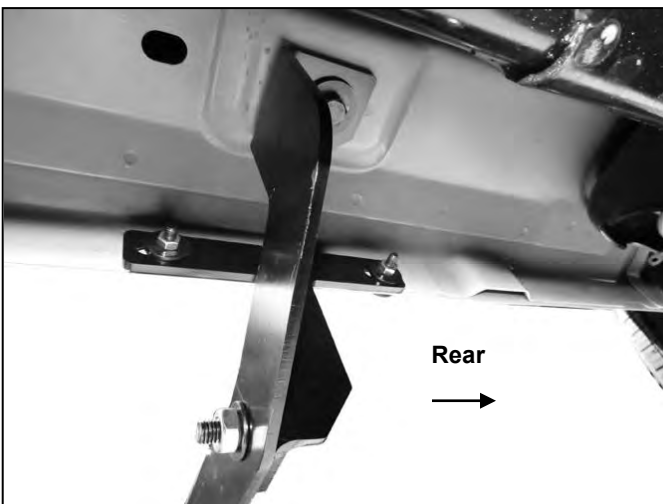

(Fig 7) Passenger/right side Rear Brackets installed

### Passenger Side Installation Pictured

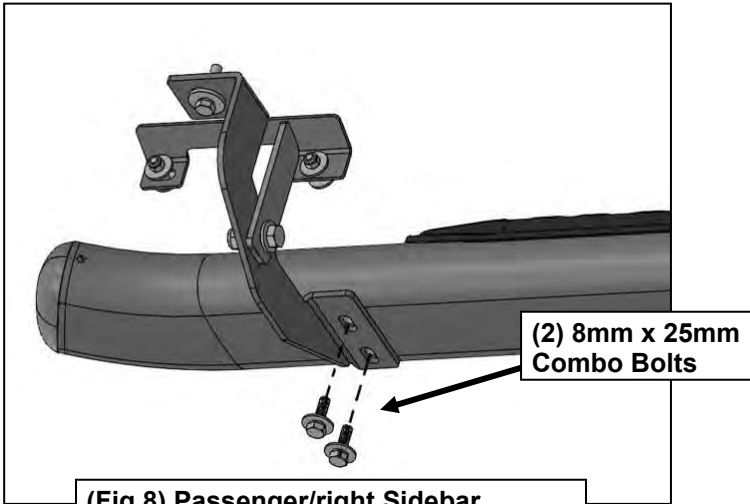

(Fig 8) Passenger/right Sidebar attached to Front Brackets illustrated

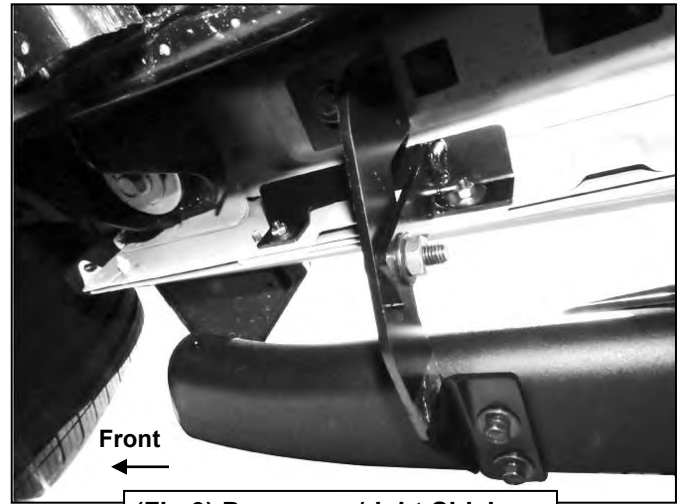

(Fig 9) Passenger/right Sidebar attached to Front Brackets

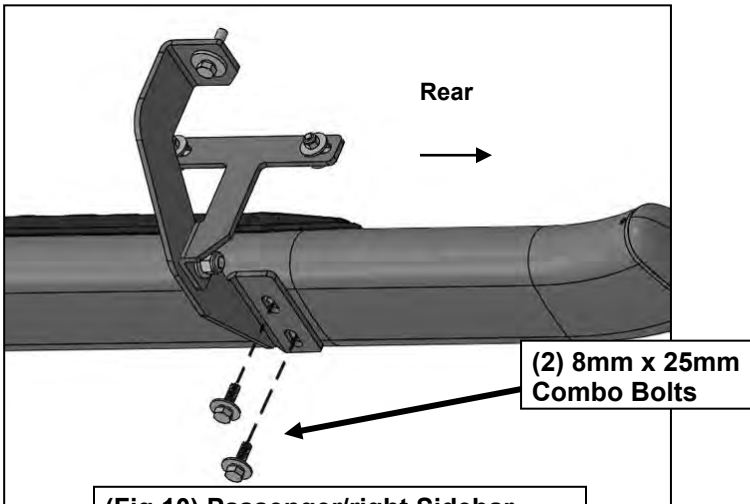

(Fig 10) Passenger/right Sidebar attached to Rear Brackets illustrated

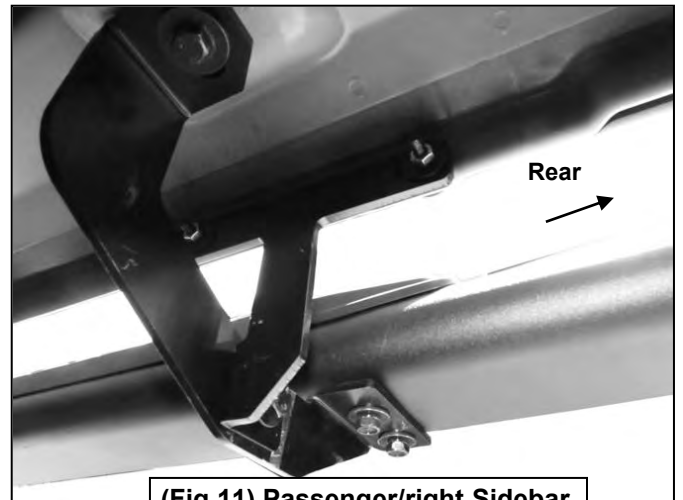

(Fig 11) Passenger/right Sidebar attached to Rear Brackets



Complete Installation