

PARTS LIST:

1	Receiver Towing Hitch	6	12mm x 32mm x 3mm Flat Washers
1	Trailer Connection Tab	2	12mm Lock Washers
4	12-1.75mm x 120mm Hex Bolts	2	12-1.75mm Nylon Lock Nuts

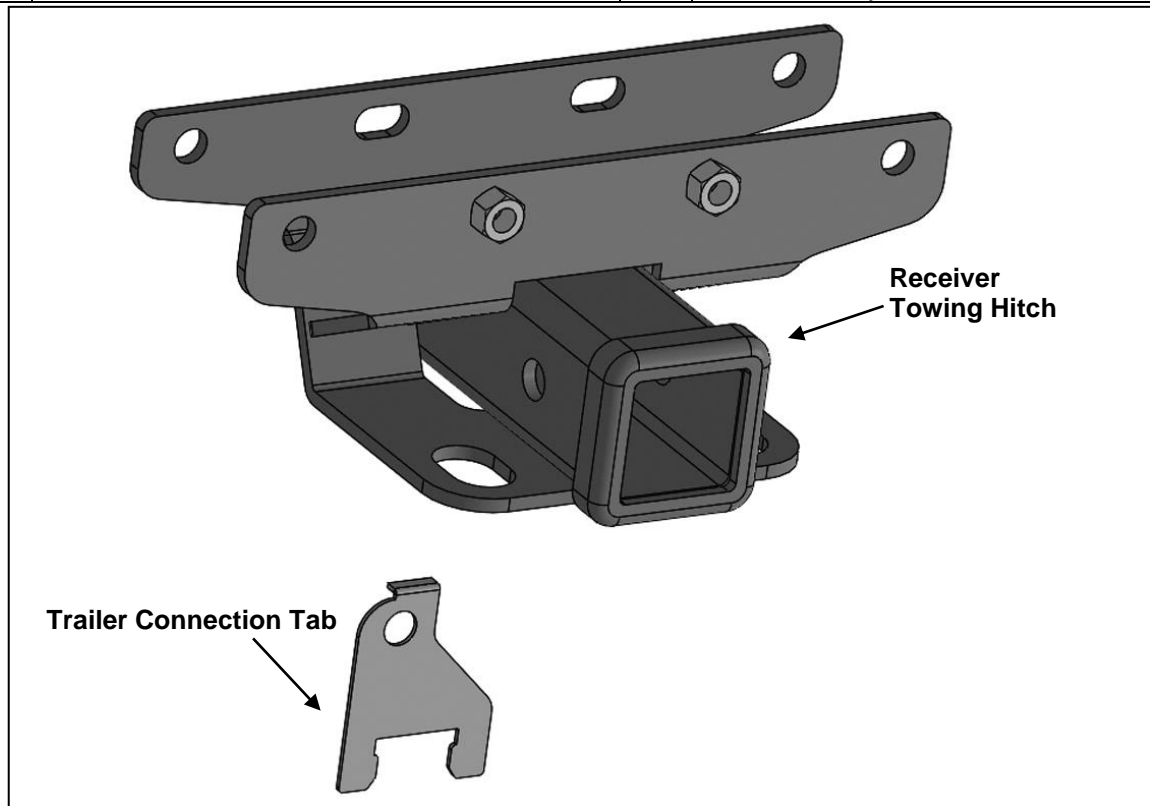

PROCEDURE:

REMOVE CONTENTS FROM BOX. VERIFY ALL PARTS ARE PRESENT. READ INSTRUCTIONS CAREFULLY BEFORE STARTING INSTALLATION.

1. Locate the frame underneath the Rear Bumper, **(Figure 1)**. Determine if the Bumper is equipped with an L-Shaped Bracket connecting the Bumper to frame, **(Figure 2)**.

Models equipped with an L-shaped Bracket:

- a. Remove the factory bolts attaching the Bracket to the Bumper and frame, **(Figure 1)**.
- b. Select the Receiver Hitch. Hold the Receiver Hitch up to the frame and align the holes on the Hitch to the frame. **NOTE:** The inner welded nuts on the Hitch will be facing the rear.
- c. Insert (2) 12mm Hex Bolts, (2) 12mm Lock Washers and (2) 12mm Flat Washers in through the inner slots on the Hitch, all through the frame and thread out through the welded nuts on the Hitch, **(Figure 3)**. Snug but do not tighten hardware.
- d. Next, loosen the (4) factory bumper bolts to help aid in L-shaped Bracket reinstallation, **(Figure 4)**. Slide the L-shaped Bracket between the Bumper and Receiver Hitch, **(Figure 5)**.
- e. If installing the Trailer Connection Tab, hang and align the Tab over the driver/left side outermost hole on the Hitch, **(Figure 3)**. **NOTE:** The Trailer Tab will be installed between the Receiver Hitch and the L-shaped Bracket.
- f. Insert the (2) long factory bolts in through the outer holes on the Hitch, all through the frame, out the other side of the Hitch and thread out through the welded nuts on the L-shaped Bracket, **(Figure 6)**. **NOTE:** All Bolts will face towards the rear end of the vehicle. Do not tighten hardware at this time.
- g. Once the L-shaped Bracket has been reinstalled, tighten the factory bumper bolts.

Models without L-shaped Bracket:

- a. Hold the Receiver Hitch up to the frame and align the holes on the Hitch to the frame. **NOTE:** The inner welded nuts on the Hitch will be facing the rear.

- b. Insert (2) 12mm Hex Bolts, (2) 12mm Lock Washers and (2) 12mm Flat Washers in through the inner slots on the Hitch, all through the frame and thread out through the welded nuts on the Hitch, **(Figures 7 & 8)**. Snug but do not tighten.
 - c. Next, insert (2) 12mm Hex Bolts and (2) 12mm Flat Washers in through the outer holes on the Hitch, all through the frame and out the other side of the Hitch, **(Figures 7 & 8)**.
 - d. If installing the Trailer Connection Tab, hang and align the Tab over the driver/left side outermost hole on the Hitch, **(Figures 7 & 8)**.
 - e. Secure the (2) outer 12mm Hex Bolts to the frame and Hitch using (2) 12mm Flat Washers and (2) 12mm Nylon Lock Nuts, **(Figures 7 & 8)**.
2. Center and adjust the Receiver Hitch and fully tighten all hardware.
 3. Attach the trailer harness to the Trailer Connection Tab, if installed.
 4. Do periodic inspections of the installation to make sure that all hardware is secure and tight.

To protect your investment, wax this product after installing. Regular waxing is recommended to add a protective layer over the finish. Do not use any type of polish or wax that may contain abrasives that could damage the finish. Use mild soap to clean the Receiver Hitch.

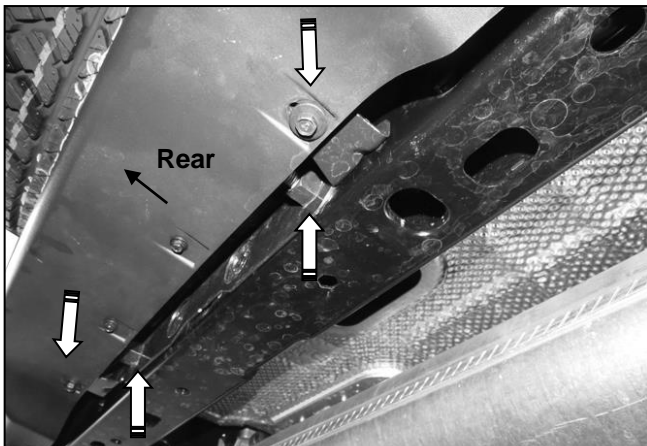

(Fig 1) Remove the L-shaped bracket connecting the bumper to the frame, if equipped.

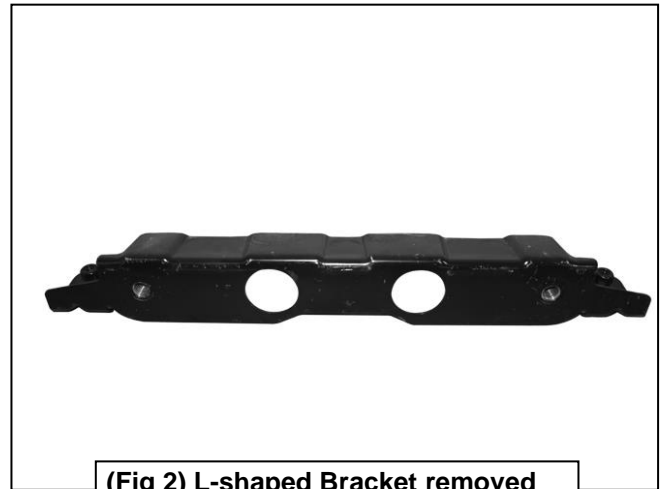

(Fig 2) L-shaped Bracket removed

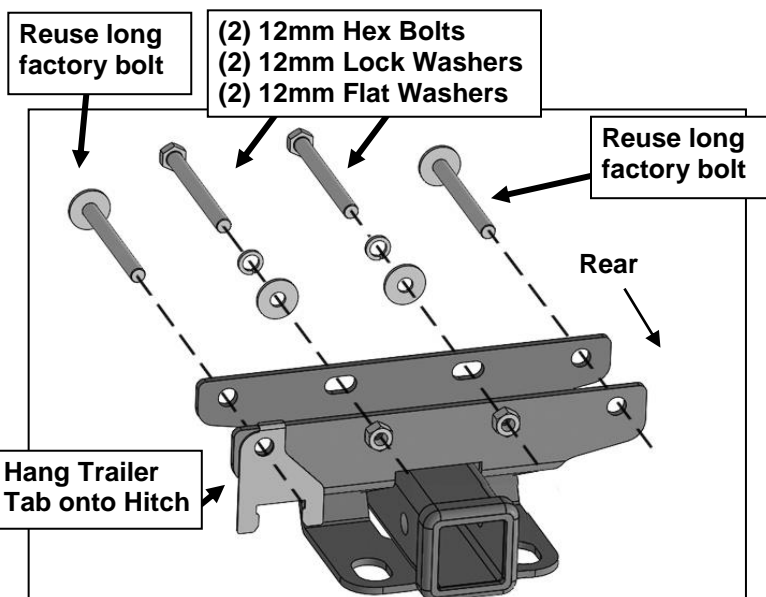

(Fig 3) Receiver Towing Hitch assembly with factory L-shaped Bracket and Trailer tab



(Fig 4) Loosen the factory bumper bolts, (2 per side) to help reinstall L-shaped Bracket

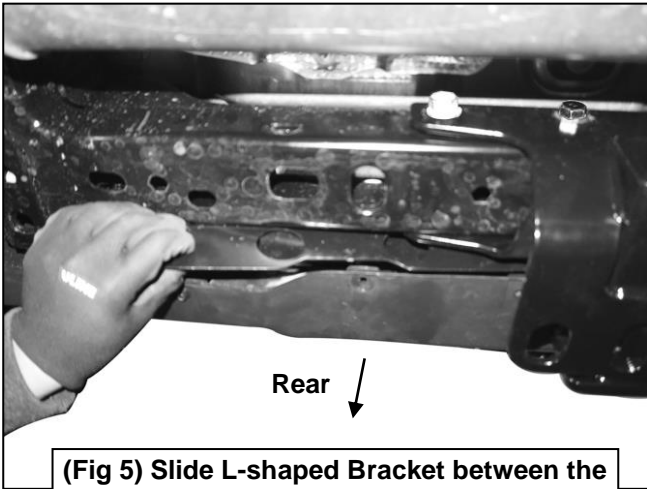

(Fig 5) Slide L-shaped Bracket between the bumper and the Receiver Hitch

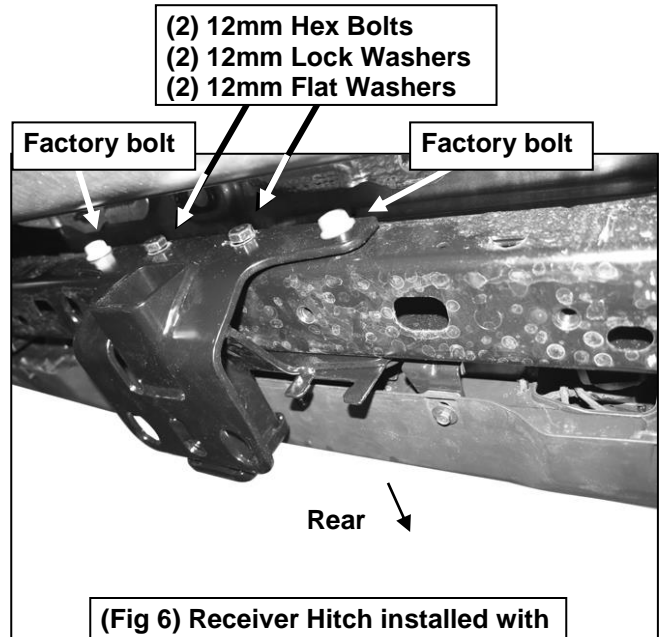

(Fig 6) Receiver Hitch installed with Trailer Tab and L-shaped Bracket

Inner slots on Hitch:
(2) 12mm Hex Bolts
(2) 12mm Lock Washers
(2) 12mm Flat Washers

Outer holes on Hitch:
(2) 12mm Hex Bolts
(4) 12mm Flat Washers
(2) 12mm Nylon Lock Nuts

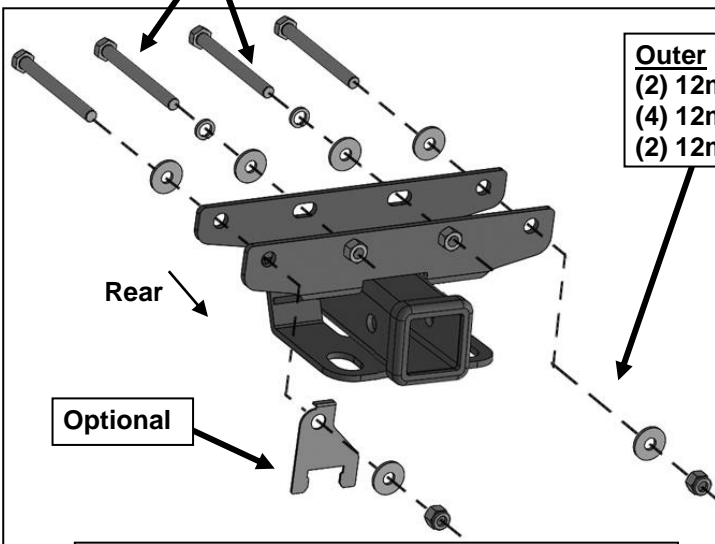

(Fig 7) Receiver Hitch assembly with Trailer Connection Tab and no L-shaped Bracket



(Fig 8) Receiver Hitch installed with Trailer Tab