

REDROCK^{4X4}

HD Drop Steps (07-18 JK 2-Door)

PARTS LIST:

1	Driver/left NB1 Running Board	16	10mm x 27mm x 3mm Flat Washers
1	Passenger/right NB1 Running Board	4	10mm Lock Washers
1	Driver/left Front Mounting Bracket	8	10-1.5mm Nylon Lock Nuts
1	Passenger/right Front Mounting Bracket	4	8-1.25mm x 35mm Hex Bolts
1	Driver/left Rear Mounting Bracket	4	8mm x 28mm x 3mm Flat Washers
1	Passenger/right Rear Mounting Bracket	4	8mm Lock Washers
4	10-1.5mm Nut Plates	8	6-1.0mm x 25mm Hex Bolts
12	10-1.5mm x 35mm Hex Bolts	16	6mm x 22mm x 2mm Flat Washers
4	10mm x 34mm x 3mm Flat Washers	8	6-1.0mm Nylon Lock Nuts

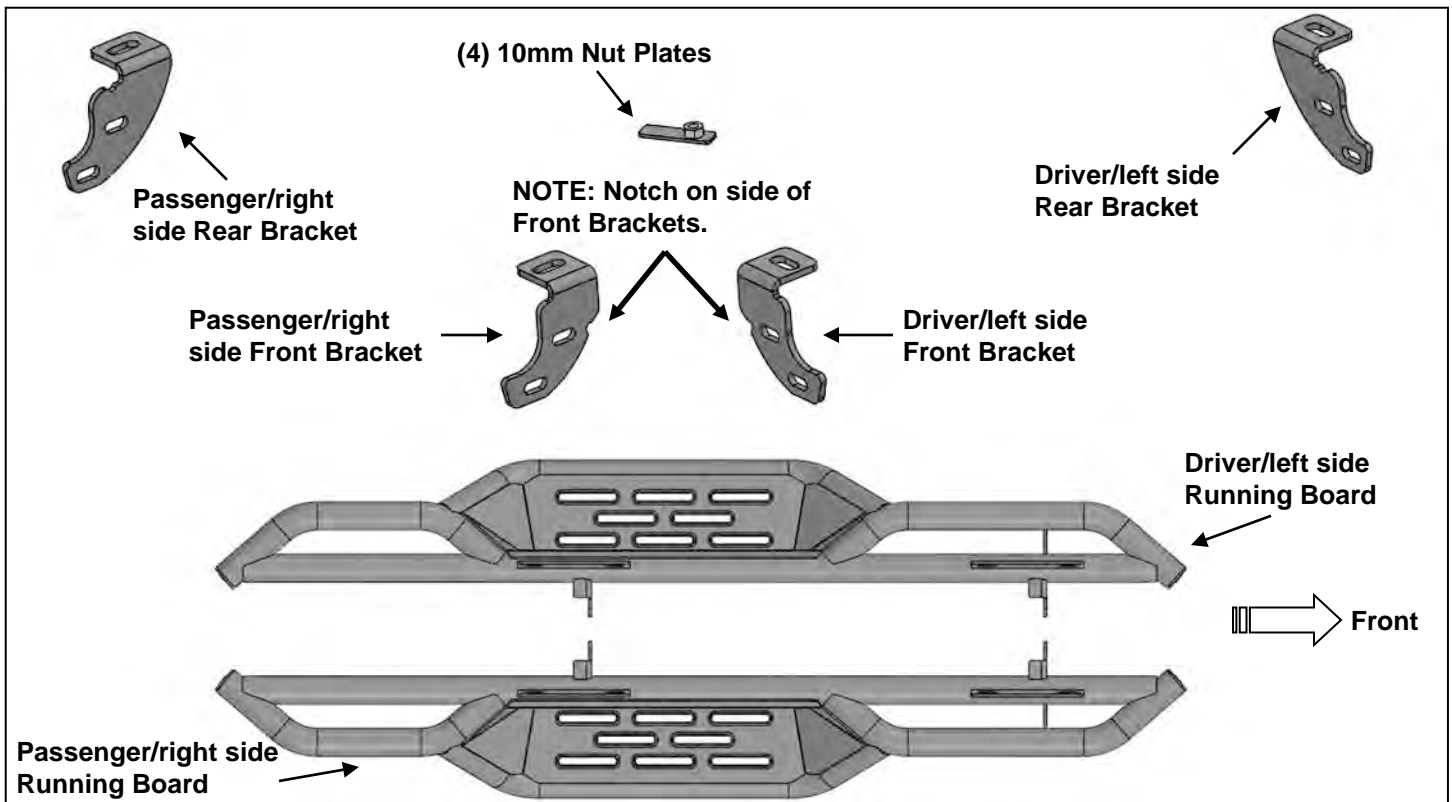

PROCEDURE:

- REMOVE CONTENTS FROM BOX. VERIFY ALL PARTS ARE PRESENT. READ INSTRUCTIONS CAREFULLY. FACTORY INSTALLED OR AFTERMARKET "ROCK RAILS," SIDE STEPS OR RUNNING BOARDS MUST BE REMOVED.
- Start installation toward the front of the passenger side of the vehicle. Determine if the vehicle has an open floor panel or a threaded hole in the floor panel, (Figures 1 & 4).

Vehicles with open mounting location:

 - Insert (1) 10mm Nut Plate into the large square opening in the floor panel. Line up the threaded nut with the hole in between the pair of holes on the pinch weld, (Figures 1A, 1B & 2).
 - Move along to the rear mounting location, (Figure 3). Repeat **Step 2a** to insert the Nut Plate into the rear opening on the floor panel.

Vehicles with factory threaded hole in floor panel:

 - Locate the front and rear mounting locations, (Figures 4 & 5). Continue to **Step 3**.
- Select and place the passenger/right side Front Bracket and the passenger/right side Running Board on a stable clean flat surface. **NOTE:** Use the illustration above to help determine the correct Bracket

and Running Board. Use the included (2) 10mm Hex Bolts, (4) 10mm x 27mm Flat Washers and (2) 10mm Nylon Lock Nuts to attach the rear facing side of the Bracket to the front side of the welded bracket on the Running Board, **(Figure 6)**. Do not tighten hardware at this time.

4. Repeat **Step 3** to attach the passenger Rear Bracket to the front side of the Running Board.
5. With assistance, position the mounting plates on the Running Board with the attached Mounting Brackets up to the **back** of the pinch weld. Line up the mounting plates on the Running Board with the (2) pairs of holes on the pinch weld, **(Figures 7—9)**.
6. Secure the Running Board to the **back** of the pinch weld using (4) 6mm Hex Bolts, (8) 6mm Flat Washers and (4) 6mm Nylon Lock Nuts, **(Figures 7—9)**. **NOTE:** Insert bolts from the outside of the pinch weld and through the mounting plate.
7. **Vehicles with open mounting location:** Bolt the tab on the Mounting Brackets to the Nut Plates with (2) 10mm x 35mm Hex Bolts, (2) 10mm Lock Washers and (2) 10mm x 34mm Large Flat Washers, **(Figure 10)**. Do not tighten hardware at this time.
8. **Vehicles with factory threaded hole in floor panel:** Bolt the tab on the Mounting Brackets to the threaded holes in the floor panel with (2) 8mm x 35mm Hex Bolts, (2) 8mm Lock Washers and (2) 8mm x 28mm Large Flat Washers, **(Figures 11—13)**. Do not tighten hardware.
9. Level and adjust the Running Board and tighten all hardware.
10. Repeat **Steps 2—9** for Driver/left side Running Board installation.
11. Do periodic inspections to the installation to make sure that all hardware is secure and tight.

To protect your investment, wax this product after installing. Regular waxing is recommended to add a protective layer over the finish. Do not use any type of polish or wax that may contain abrasives that could damage the finish. Mild soap may be used to clean the Running Board.

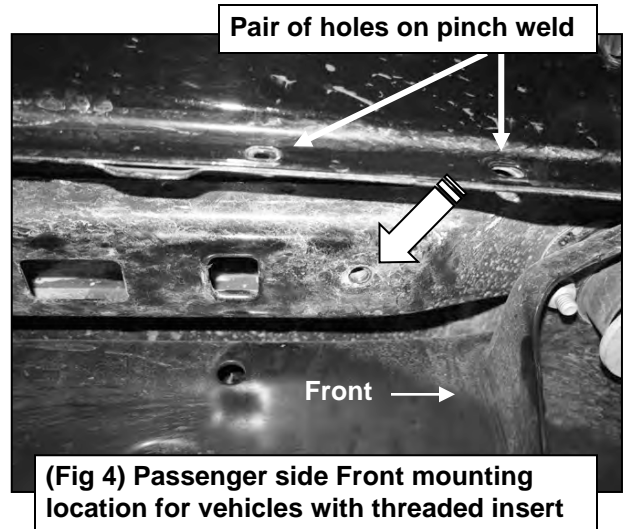
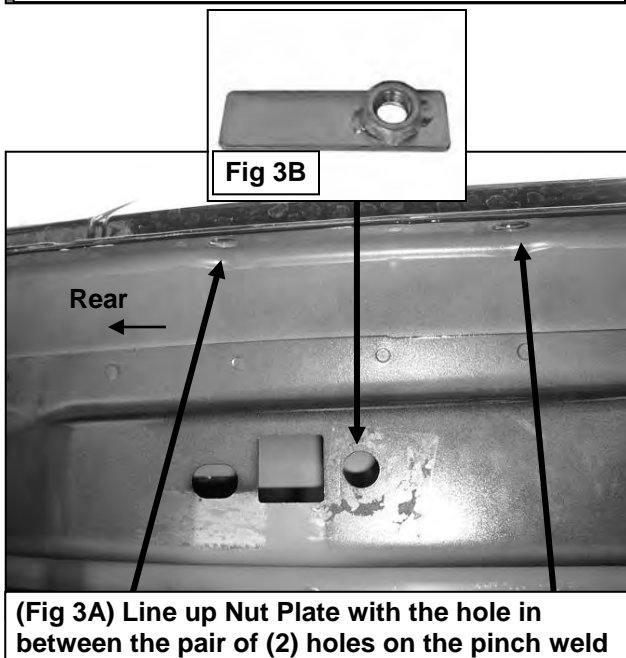
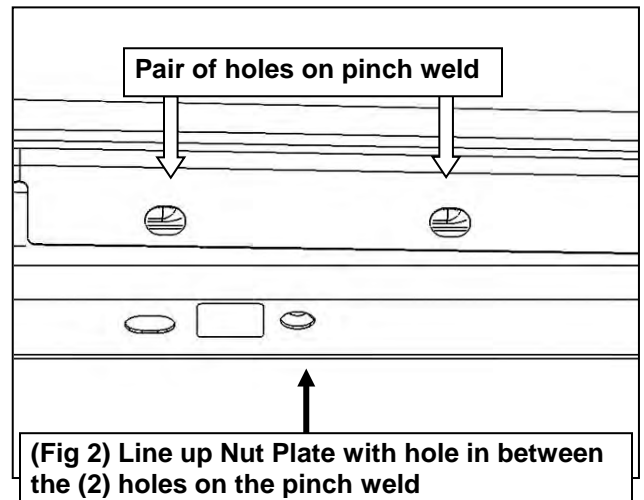
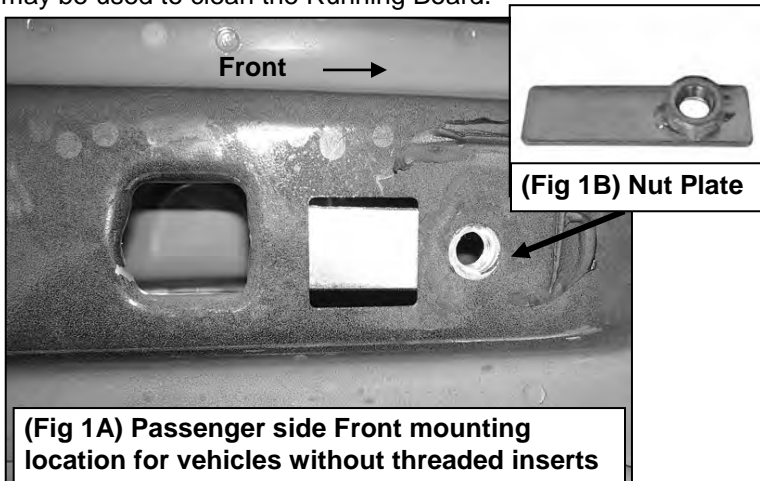

Passenger Side Installation Pictured

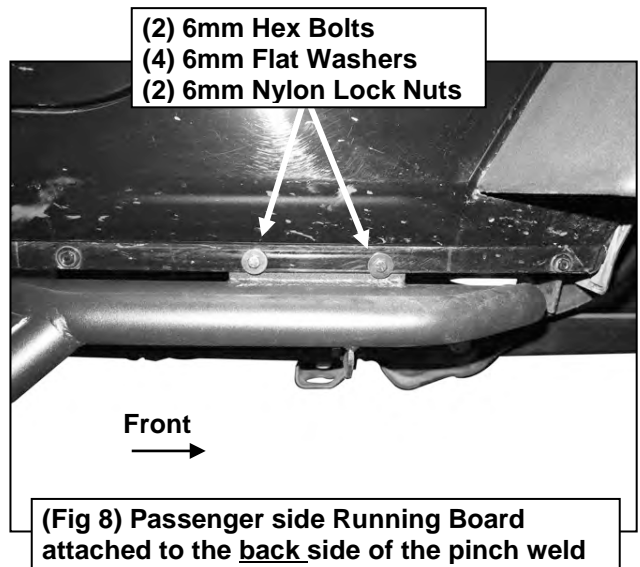
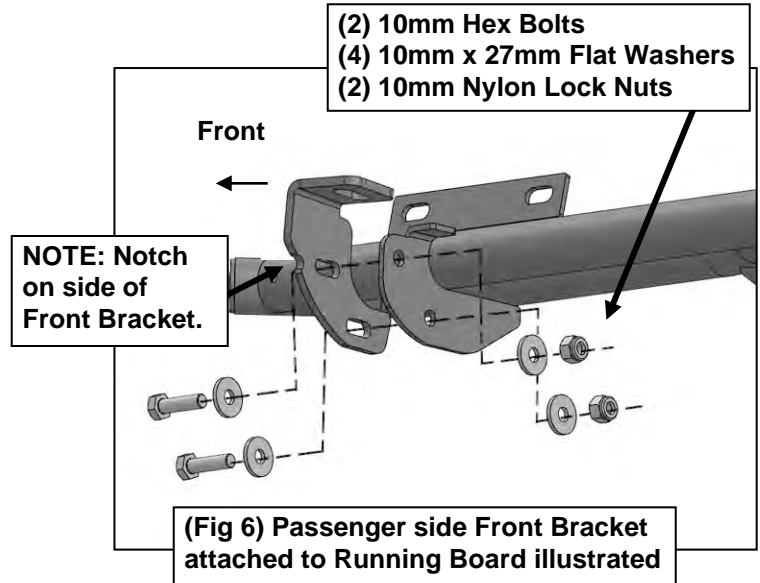
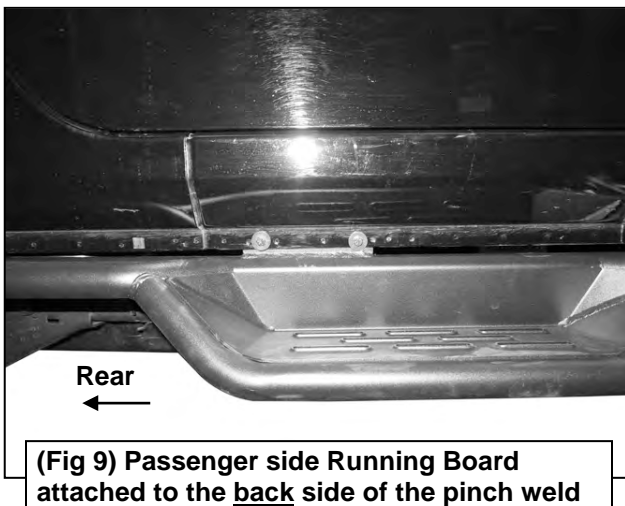
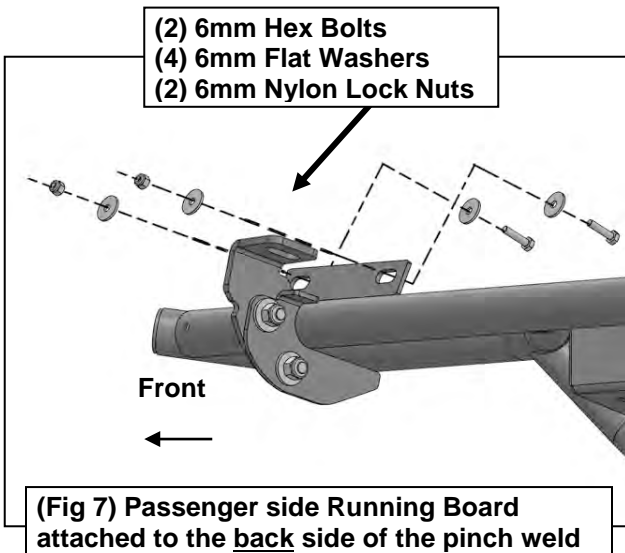
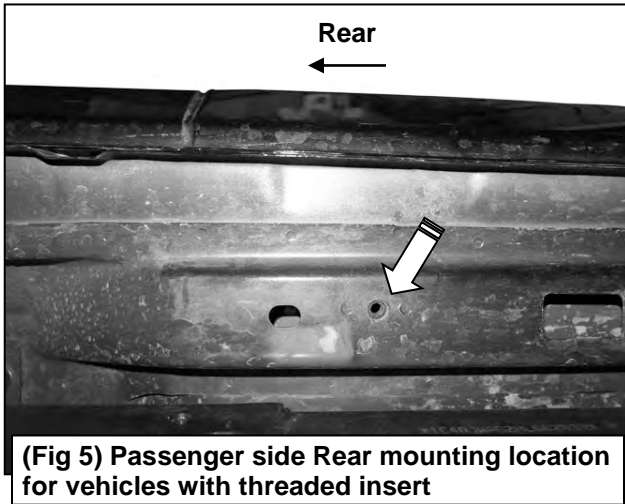

Passenger Side Installation Pictured

Use Nut Plate for models without threaded insert

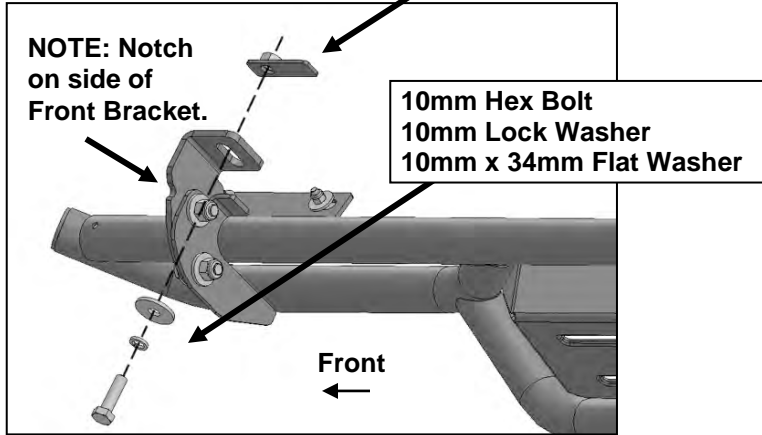

(Fig 10) Passenger/right side Front Bracket illustrated for vehicles without threaded insert

Vehicles with threaded insert:
8mm Hex Bolt
8mm Lock Washer
8mm Flat Washer

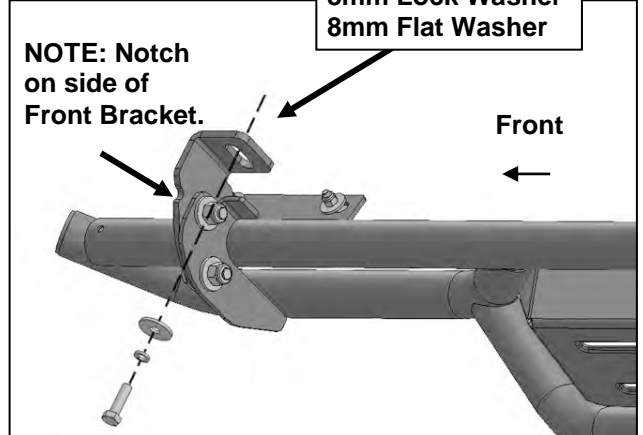

(Fig 11) Passenger/right side Front Bracket illustrated for vehicles with threaded inserts

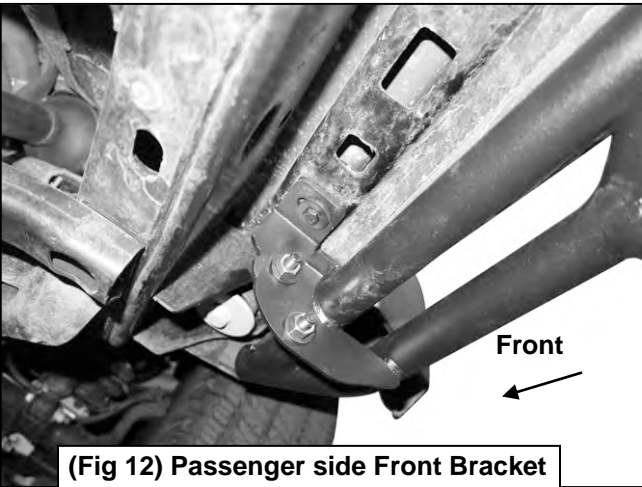

(Fig 12) Passenger side Front Bracket attached to Running Board

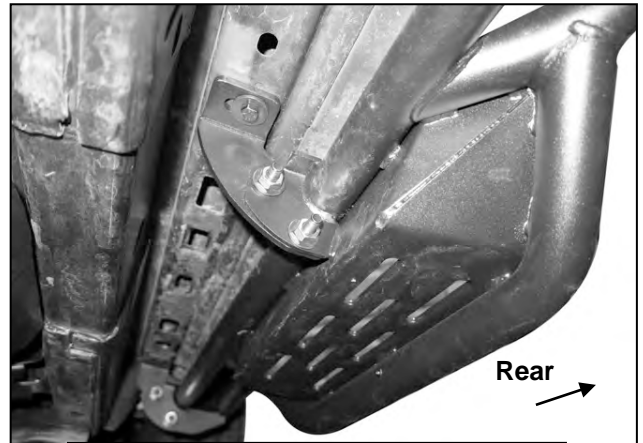

(Fig 13) Passenger side Rear Bracket attached to Running Board

