

TJ Windshield Header Channel Installation Instructions Wrangler 1997-2006

Do Not Install on any vehicles other than those listed above.

Parts List: (2) 1 1/4" Hex Head Bolts (2) 5/16" Flat Washer
(2) J-Hook Bracket (1) Header Bar



WARNING: This product is designed to enhance the look of your vehicle. Do not rely on the components of this kit to protect or contain passengers or cargo within the vehicle, or to protect against injury or death during an accident.

WEAR SEAT BELTS AT ALL TIMES:

Read and follow instructions prior to installation. Failure to do so could put driver and passengers in potential danger. After installing or reinstalling, double check with installation instructions to make sure all steps were followed.

Tools required: (1) 1/2" Wrench or Socket.

Step one:

Place the windshield retainer assembly on top of the bulb seal located along the top of the windshield. Locate the two J-hook brackets and orient them with the hooks towards the front of the channel and the threaded inserts facing upwards as seen in (Fig.1).

Step two:

Slide the J-hook bracket onto the windshield retainers J-hook mounting base making sure to catch the hook in the windshield slot. Insert a 5/16" x 1 1/4" Hex Head Bolt and 5/16" Flat Washer into the top into J-hook bracket. Secure the bracket to the retainer base using 1/2" wrench. Repeat this step for the other side (Fig.2).

Fig.1

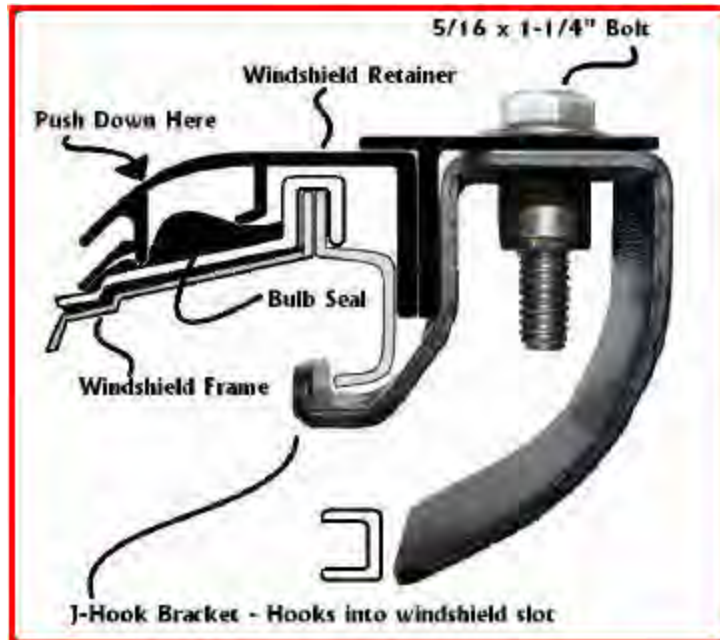

Caution!
Safety Glasses should be worn at all times while installing this product.

Fig.2



NOTE: While installing the windshield retainer J-hook bracket assembly, apply **FIRM** pressure towards the front of vehicle to make sure that the assembly is installed correctly.