

JK Windshield Channel Header

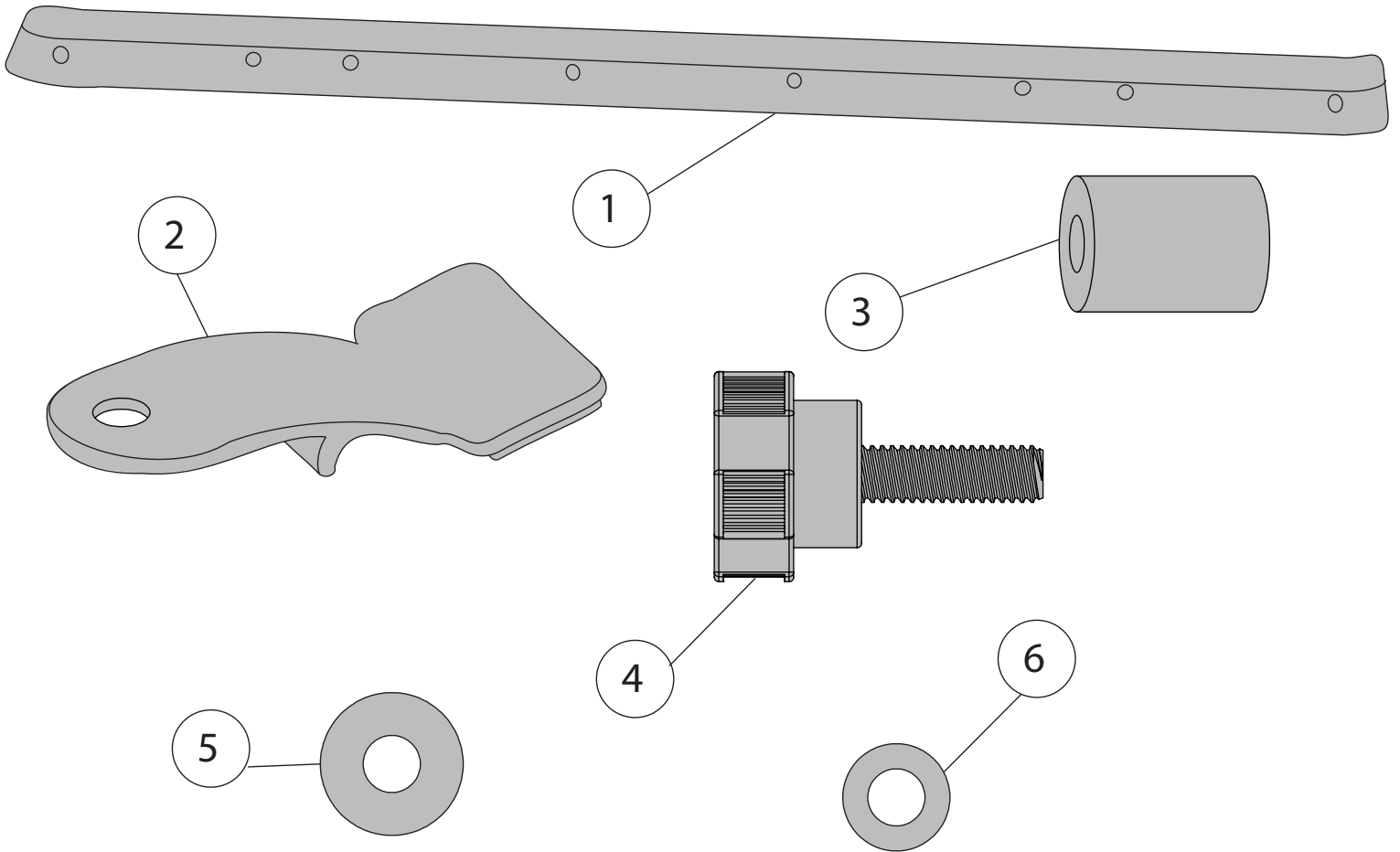

Components

- | | |
|-------------------------------|-----|
| 1. Steel (J105218) Header Bar | (1) |
| 2. Retainer Arm | (2) |
| 3. Metal Spacer | (2) |
| 4. Threaded Lock Knob | (2) |
| For 13308.05 Only: | |
| 5. Large Nylon Washer | (2) |
| 6. Small Nylon Washer | (2) |

JK Windshield Channel Header

1. Stack metal spacer between bracket and header; 13308.05 will require one large and one small nylon washer on each side. Do not fully tighten knobs at this time.

NOTICE Washers are not required for Steel Header (J105218)

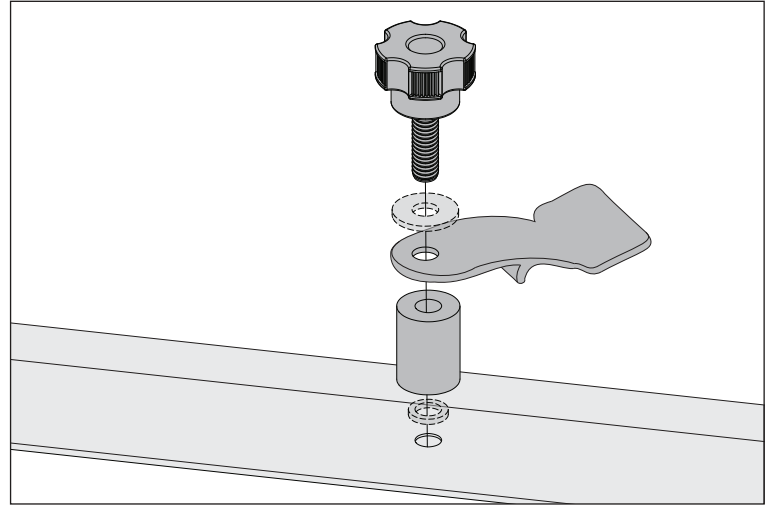

2. Place header into front mounting pocket of top. Rubber pads should be pointing toward the back of the top as shown.

3. With header slid fully into mounting pocket, secure top snaps to header channel.

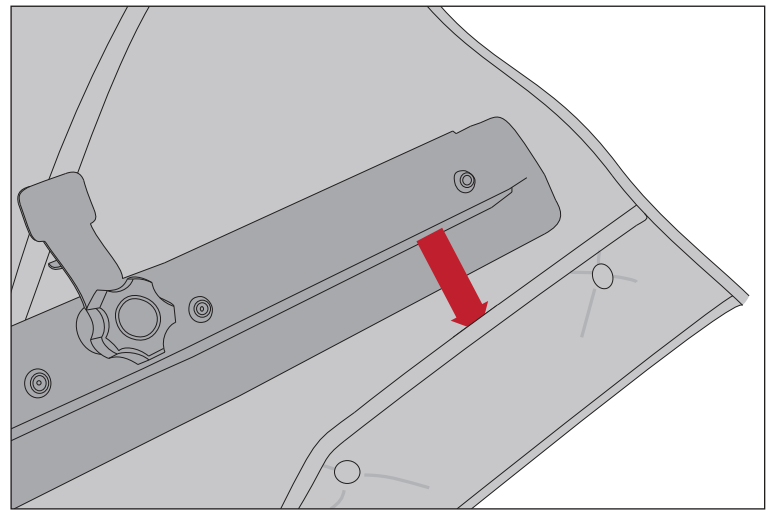

4. Carefully place header and top onto vehicle, ensuring assembly does not scratch or damage windshield. The top and header should rest just behind leading edge of rubber windshield seal.

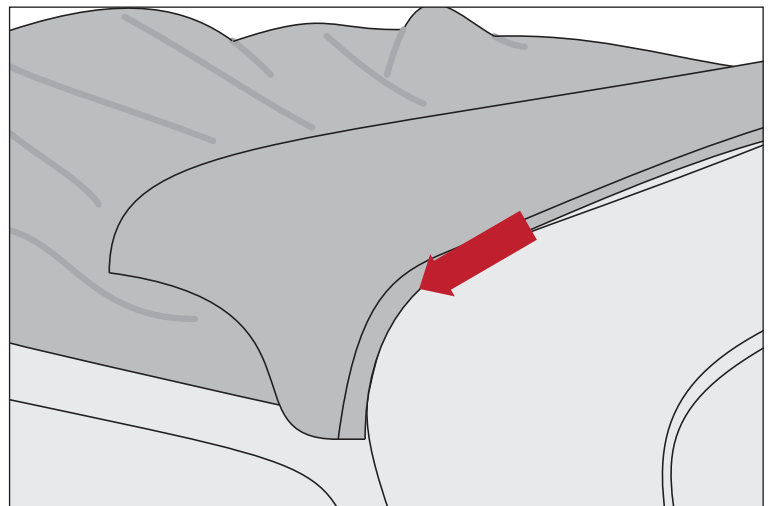

JK Windshield Channel Header

5. From inside vehicle, rotate retainer arms over windshield clamp bracket. Tab should rest behind clamp bracket on windshield frame. Foam pads on retainer arms will rest on windshield frame.

⚠ WARNING Tab located on Retainer Arm should hook through windshield frame footman loop to prevent Header Bar from dislocation during operation.

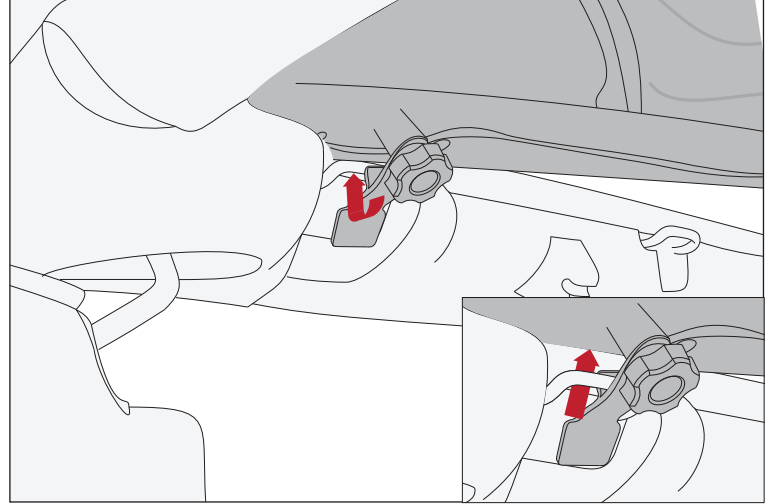

6. Tighten retainer arms by turning threaded lock knobs clockwise. Alternate between the left and right knobs to ensure tight fit.

Do not overtighten.

Top and header should be tight to windshield rubber seal.

7. Finish installing top per manufacturer's instructions.

