

## 2010-2015 Jeep Wrangler 4Dr/2Dr 3-1/2" Oval Bull Bar

### PARTS LIST:

1	3.5" Bull Bar	2	12mm Hex Nuts
1	Driver/Left Mounting Bracket	4	8-1.25mm x 35mm Hex bolts
1	Passenger/Right Mounting Bracket	4	8mm x 22mm x 2mm Flat Washers
1	Driver/Left Support Bracket	4	8mm Lock Washers
1	Passenger/Right Support Bracket	2	Light Brackets
2	12mm Double Nut plates	4	6-1.0mm x 20mm Button Head Bolts
2	12-1.75 x 40mm Hex bolts	4	6mm x 18mm OD x 1.6m Flat Washers
4	12-1.75 x 30mm Hex Bolts	4	6mm Lock Washers
8	12mm x 24mm OD x 2.5mm Flat Washers	1	Allen Wrench
6	12mm Lock Washers		

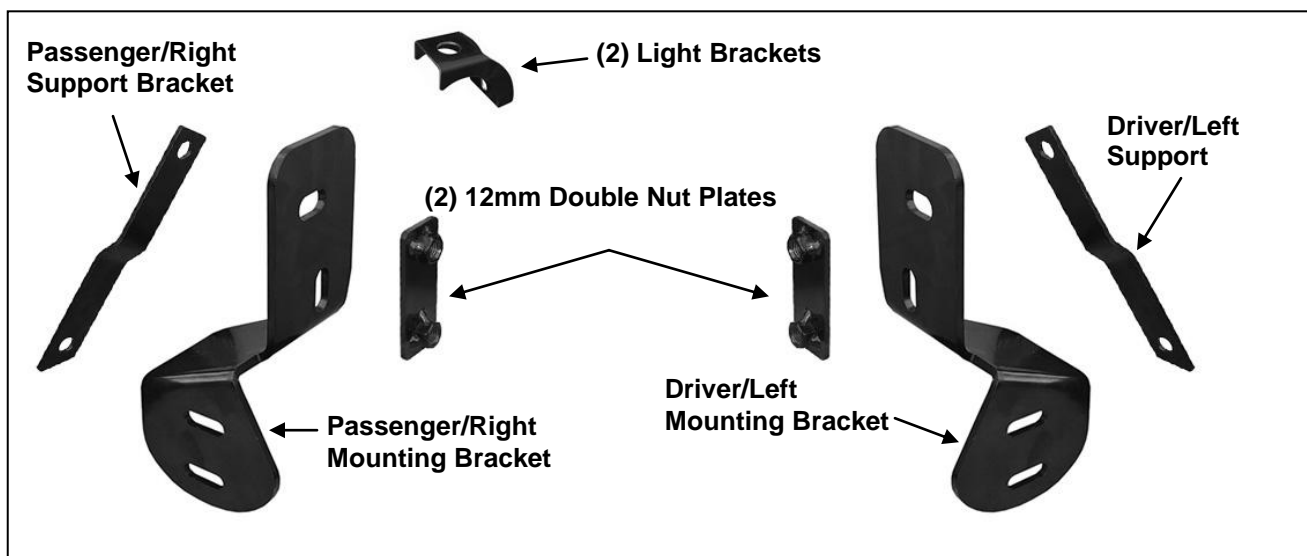

### PROCEDURE:

- REMOVE CONTENTS FROM BOX. VERIFY ALL PARTS ARE PRESENT. READ INSTRUCTIONS CAREFULLY. CUTTING IS REQUIRED. ASSISTANCE IS RECOMMENDED.**
- Remove the plastic splash guard from under the front bumper and place it on a clean, stable work surface, **(Figure 1)**.
- Starting on the driver side, insert (1) 12mm Double Nut Plate, **(Figure 2)**, into the opening in the end of the frame cross-member. Line up the lower hole in the Nut Plate with the lower hole in the frame.
- Select the driver side Mounting Bracket. Insert (1) 12mm x 30mm Hex Bolt, (1) 12mm Lock Washer Flat Washer and (1) 12mm Flat Washer through the lower hole in the Bracket, cross-member and into the Double Nut Plate, **(Figure 3)**. Leave hardware loose at this time.
- Next, select the driver side Support Bracket. Attach the Support Bracket to the upper hole in the Mounting Bracket with (1) 12mm x 40mm Hex Bolt, (1) 12mm Lock Washer and (1) 12mm Flat Washer inserted through the Support Bracket, the upper hole in the Mounting Bracket, cross-member and into the upper hole in the Nut Plate, **(Figure 4)**. Snug but do not tighten the hardware at this time.
- Repeat **Steps 3—5** for passenger side Mounting Bracket installation.
- With assistance, position the Bull Bar up to the Mounting Brackets. Use the included (4) 8mm x 35mm Hex Bolts, (4) 8mm Lock Washers and (4) 8mm Flat Washers to attach the Bull Bar to the Mounting Brackets, **(Figure 5)**. Do not tighten hardware at this time.
- Bolt the forward end of the Support Brackets onto the outside of the tabs on the Bull Bar with the included (2) 12mm x 30mm Hex Bolts, (4) 12mm Flat Washers, (2) 12mm Lock Washers and (2) 12mm Hex Nuts, **(Figures 5 & 6)**. Snug but do not fully tighten hardware at this time.

9. Align the Bull Bar properly and fully tighten the Bracket hardware securing the Brackets to the frame only. Temporarily remove the Bull Bar.
10. Position the splash guard back up to the vehicle and attach with the factory hardware. Trace the location of the Mounting Brackets onto the splash guard, **(Figure 7)**. **NOTE:** To maintain the integrity of the plastic Splash Guard, remove only material necessary to clear the Bull Bar and Brackets. Make small cuts and check the fit often before final installation, **(Figure 8)**. Reinstall the splash guard with factory hardware.
11. Reinstall the Bull Bar and tighten all hardware.
12. Determine if accessory lights will be installed.
 

**If lights will not be installed at this time:**

  - a) Insert the included (4) 6mm x 20mm Button Head Bolts, (4) 6mm Lock Washers and (4) 6mm Flat Washers into the (4) threaded inserts in the back of the crossbar to plug the holes, **(Figure 9)**. Tighten hardware. Installation is complete.

**If aftermarket lights will be installed, (lights not included):**

  - a) Select (1) Light Mount, **(Figure 10)**. Use the hardware included with the light to attach the light to the top of the Light Mount. If light has a separate tilt feature, fully tighten base mounting hardware, **(See example Figure 11)**. If light adjusts with the base mounting hardware, skip to **Step 12b**.
  - b) Remove the rubber plug on the top of the crossbar. Bolt the light and Light Mount to the back of the Bull Bar with the included (4) 6mm x 20mm Button Head Bolts, (4) 6mm Lock Washers and (4) 6mm Flat Washers, **(Figure 11)**. **NOTE:** If light adjusts with the base mounting hardware, hand-tighten the light hardware; do not fully tighten hardware at this time. You may have to install, adjust, remove light with Bracket and readjust a few times to get the light properly adjusted.
  - c) Once properly adjusted, tighten light to Bracket hardware then tighten Bracket to Bull Bar hardware at this time.
  - d) Repeat the above **Steps 12a—12c** to install remaining light and Light Mount.
13. Do periodic inspections to the installation to make sure is secure and tight.

**To protect your investment**, wax this product after installing. Regular waxing is recommended to add a protective layer over the finish. Do not use any type of polish or wax that may contain abrasives that could damage the finish.

**For stainless steel:** Aluminum polish may be used to polish small scratches and scuffs on the finish. Mild soap may be used also to clean the Bull Bar.

**For gloss black finishes:** Mild soap may be used to clean the Bull Bar.

### Driver Side Installation Pictured

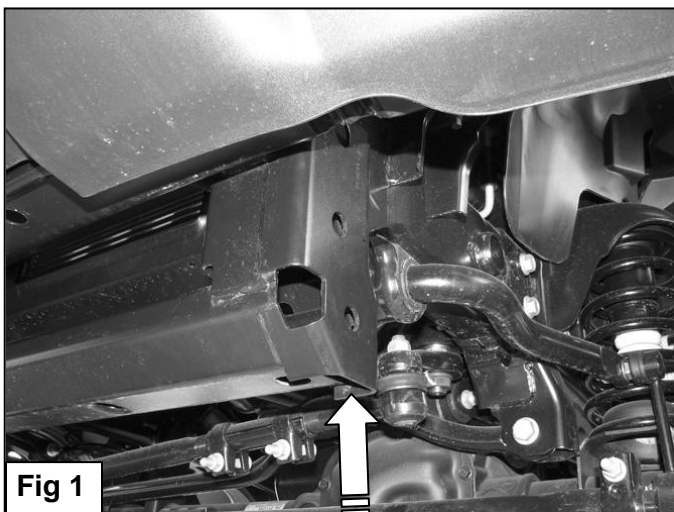

Fig 1

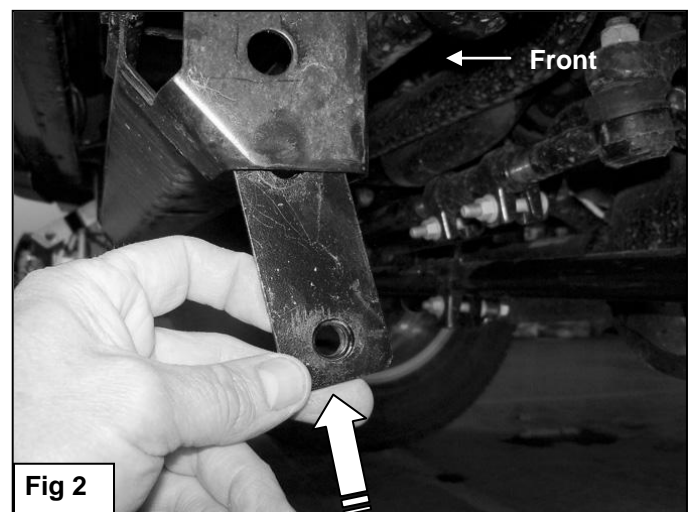
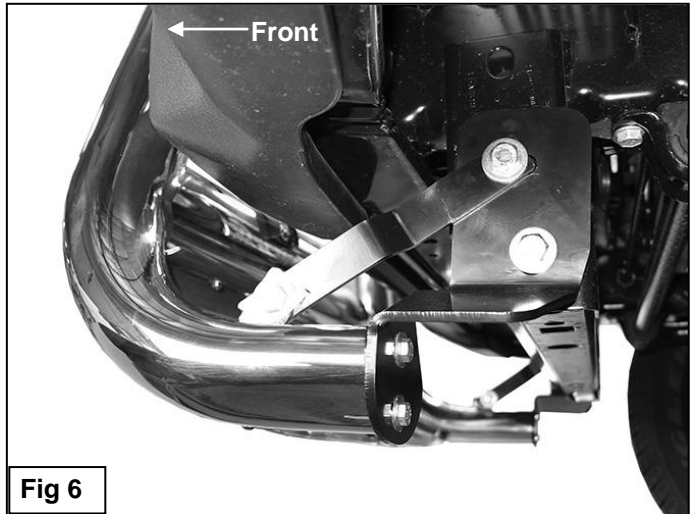
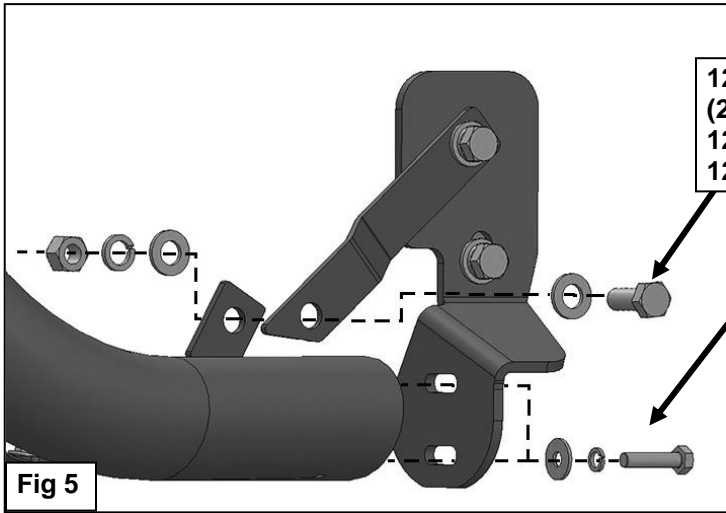
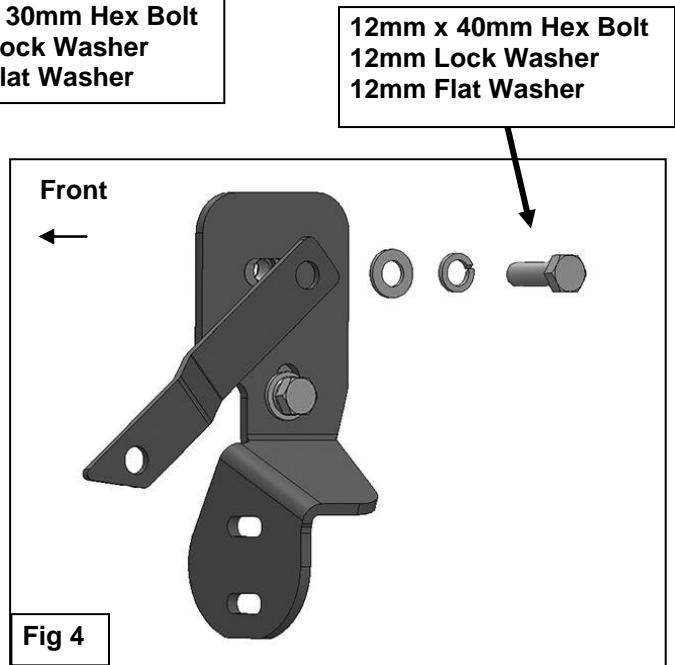
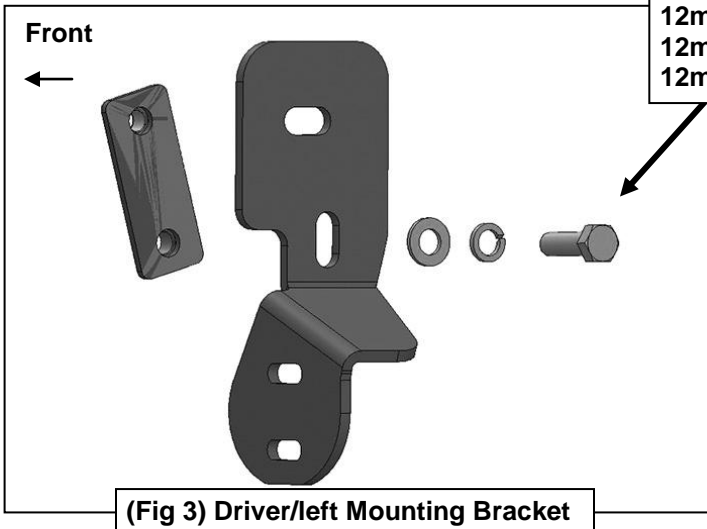

Fig 2

Insert the 12mm Double Nut Plate into the opening in the bottom of the end of the cross-member

Driver Side Installation Pictured



Cut two openings to clear the Mounting Brackets, Support Brackets and Bull Bar



Fig 8

Area to cut from splash guard illustrated for example only.



(Fig 10) Light Mounting Bracket



Fig 9

(2) 6mm x 20mm  
Button Head Bolts  
(2) 6mm Lock Washers  
(2) 6mm Flat Washers

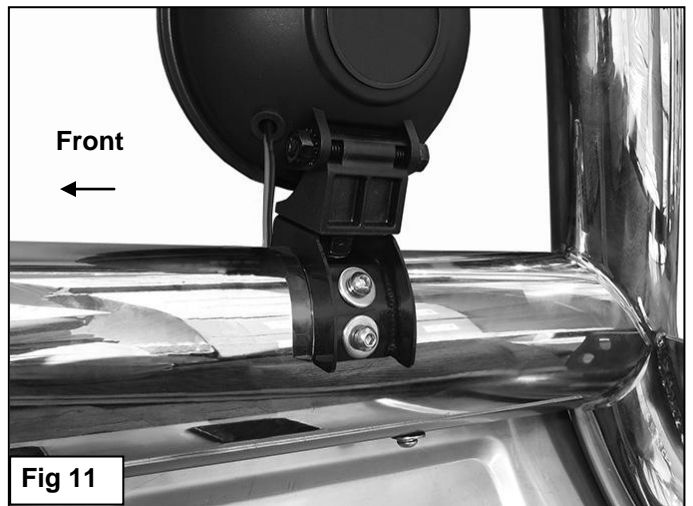

Fig 11



Installation  
Complete