



**Installation Instructions**  
**Part number 680XX Complete Top and Hardware**  
**for**  
**Jeep® Wrangler YJ 1987-95 w/ Full Steel Doors**  
**And Cj7 (with modifications)**

**IMPORTANT NOTICE:**

Carefully read instructions before attempting to install this product. Rampage Products is in no way responsible for any damage to the vehicle or personal injury that may occur during the installation or use of this product.

**WARNING**

**This product is designed to enhance the appearance of the vehicle and only for protection against the elements. Do not rely on this product to contain occupants within the vehicle or to protect against injury during an accident.**

**INCLUDED COMPONENTS**

<b><u>DESCRIPTION</u></b>	<b><u>QTY</u></b>		
Bow Assembly	1		
Windshield Channel	1	5/16" Tapping Plates	12
Side Belt Rail (Left & Right)	2	5/16" Flat Washers	12
Corner Belt Rail (Left & Right)	2	5/16" Torx Screws	12
Tailgate Brackets (Left & Right)	2	#10-24 x 1/2" Phillips Machine Scr	4
Connection Tubes	2	#10-24 Nylock Nuts	4
Soft Top	1	#10 Flat Washers	4
Behind Seat Tonneau	1	#10 Star Washers	4
Tailgate Bar	1	#8 x 1/4" Sheet Metal Screws	11
Soft Top Storage Bag	1	#8 x 1/2" Sheet Metal Screws	8
Off Road Organizer	1	#8 x 1" Sheet Metal Screws	2
Tailgate Weather strip	1	Side Rail Pin	2

**SOFT TOP INSTALLATION TIPS**

To help ease the installation, be sure to install the top when temperatures are above 70 F. The material shrinks substantially at lower temperatures and may become difficult to install. The top may seem wrinkled when first installed, this is caused by the fabric becoming wrinkled in shipping. It will relax after a few days on the vehicle.

## Replacement Top Hardware Installation Instructions

### Windshield Channel Installation

1. Position Windshield Channel onto vehicle as shown in Figure 1.
2. Once in position, secure Windshield Channel using the included (11) - #8 x 1/4" Sheet Metal Screws.  
**NOTE:** In some cases the holes on the Windshield Channel will line up with existing holes. In this case, ensure holes are not too large to install the new screws included in the package. If holes are too big, you must replace the included screws with larger screws, found at any local hardware store.  
If you are replacing a hardtop, use the Windshield Channel as a template to drill 1/8" holes.



**WARNING:** Ensure Windshield Channel is properly secured prior to installing the Soft Top. Damage to the vehicle or personal injury may occur if Windshield Channel is not securely mounted. Rampage Products is not responsible for personal injury or damage to the vehicle if Windshield Channel is not secured properly.

### Side Belt Rail Installation

1. Locate Driver Side Belt Rail, (4) – 5/16" Torx Bolts, (4) – 5/16" Flat Washers, and (4) – 5/16" Tapping Plates. Position Side Belt Rail onto vehicle and secure it using the hardware listed in this step. **NOTE: DO NOT INSTALL THE FRONT MOST TORX BOLT.** Repeat this step for opposite side. (These should mount directly into factory pre-drilled holes)

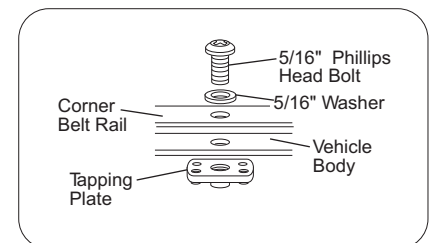
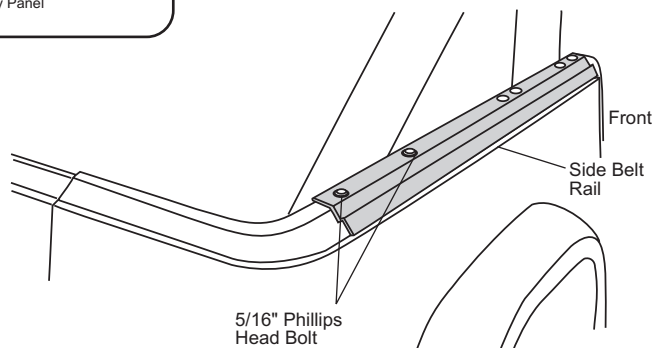
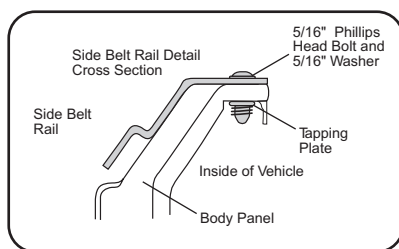

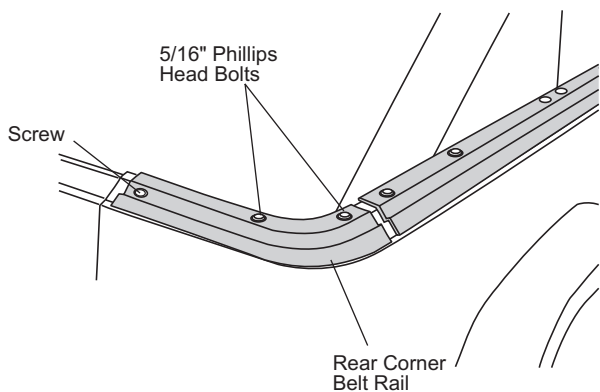

### **Corner Belt Rail Installation**

1. Locate Passenger Corner Belt Rail, (2) – 5/16” Torx Screws, (2) – 5/16” Flat Washers, and (2) – Tapping Plates. Position Corner Belt Rail onto vehicle and secure it by using hardware listed in this step. Repeat this step for opposite side. **Note:** There may be a slight gap between the Corner and Side Belt Rail. This is Normal.

### **Tailgate Brackets Installation**

1. Locate Passenger Tailgate Bracket, (2) - #10-24 x 1/2” Phillips Machine Screws, (2) - #10 star lock washers, (2) - #10 Flat Washers and (2) - #10-24 Nylock Nuts. In some cases the holes on the Tailgate Bracket will line up with existing holes. In this case, use the existing holes as pilots to drill 3/16” holes on the vehicle. **NOTE:** Carefully check under the drilling area to be sure you do not drill into any concealed wiring. **NOTE:** If you are replacing a hardtop, use the Tailgate Bracket as a template to drill 3/16” holes. Position Tailgate Bracket and secure it by using the hardware listed in this step. Repeat this step for opposite side.

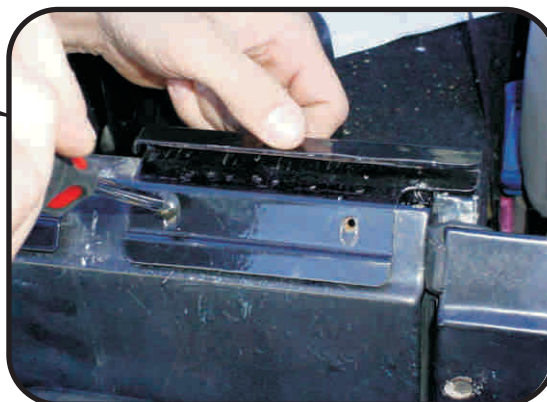
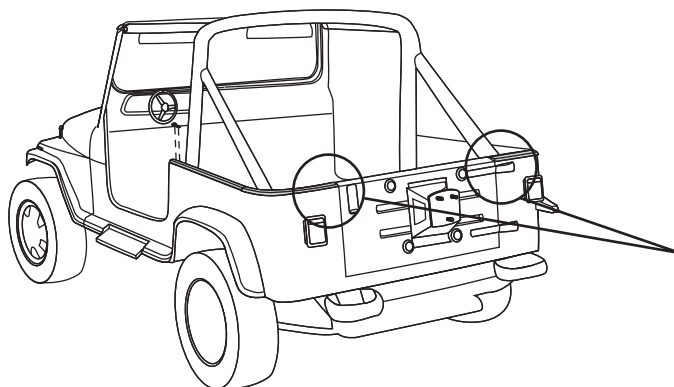

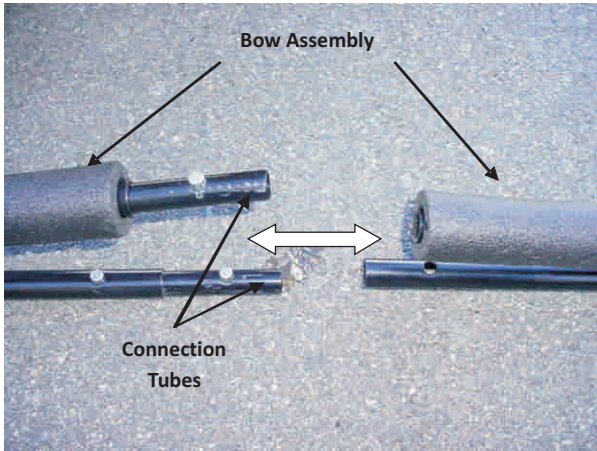

### **Bow Assembly Installation**

1. Lay Bow Assembly on a flat clean surface and identify the Front and Rear Bow.  
**NOTE:** The Front Bow will include foam padding where as the rear will not.
2. Assemble the two halves of the Bow Assembly using the included Connection Tubes with push buttons. **NOTE:** It may be helpful to use a screw flat screwdriver to push down the buttons while sliding Bow halves together. Also, it may be helpful for two persons to slide both sides of the Bow Assembly forward simultaneously.

3. With the Bow Assembly secured together, slide the ends of the front and the rear bows into the tracks in the Side Belt Rails on each side of the vehicle. **NOTE:** Slide the Bow Assembly from the rear of the vehicle towards the front. Secure Bow Ends by Inserting Side Rail Pin into Side Rail.

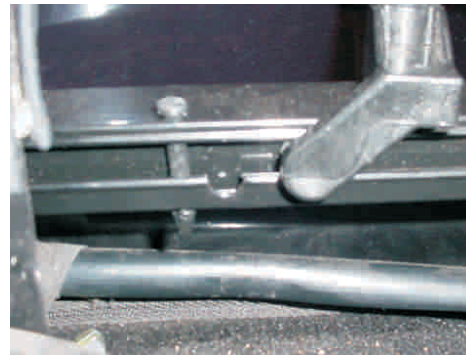
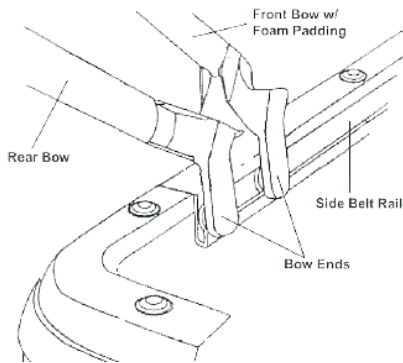

4. Unfold Passenger Upper Side Rail towards the front of the vehicle until it reaches the Passenger Upright Pin. Insert the plastic Upright's Pin through the Side Rail's hole and lock it in place by sliding the square clip to the opposite side. **NOTE:** Make sure the Upper Side Rail is properly secure prior to installing the soft top. Damage to the vehicle or personal injury can occur if not installed properly. Repeat this step for opposite side.



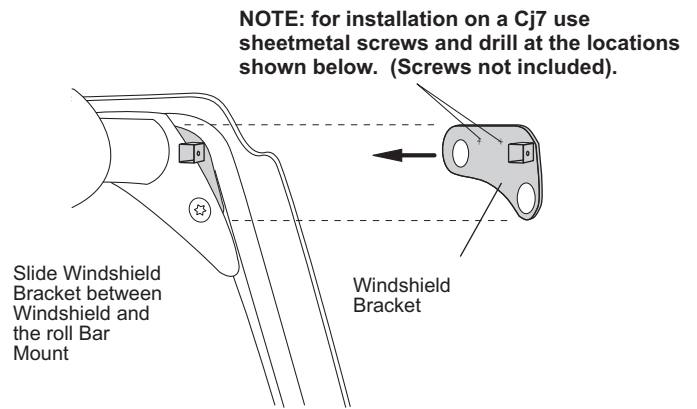
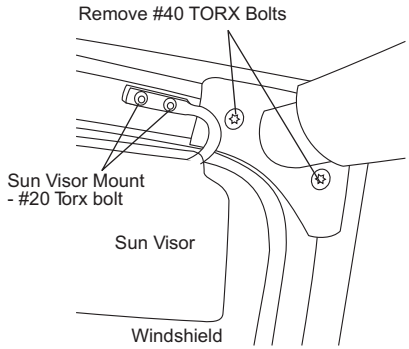

**Door frame installation:**

- 1) Loosen the visor bolts on both visors attached to the windshield.
- 2) Remove the 2 torx bolts that attach the roll bar to the windshield frame on each side of the vehicle.
- 3) Slide the sheet metal Windshield frame bracket between the roll bar mounts and the windshield then re-install the roll bar mount bolts.
- 4) Install the lower door frame mounts onto the side body channel as shown using 5/16" torx screws.
- 5) Now insert the door frame assembly into the mounts at the windshield header and at the vertical retainer mount as shown below.

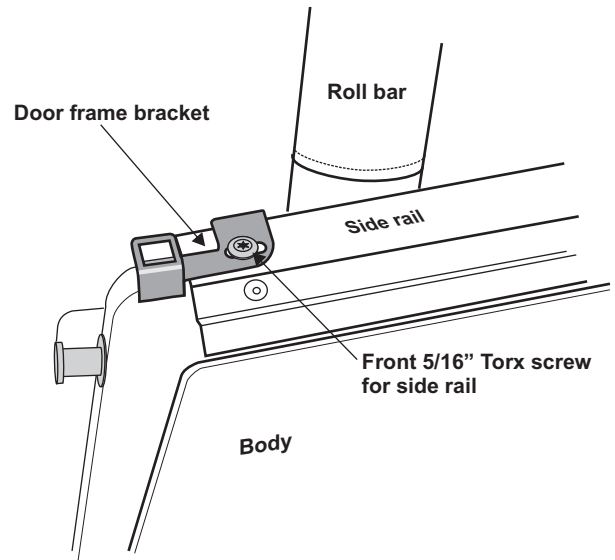

NOTE: for Cj7 additional holes must be drilled in the mounts and sheetmetal screws must be used to attach to the windshield frame. Screws not provided. (See above)

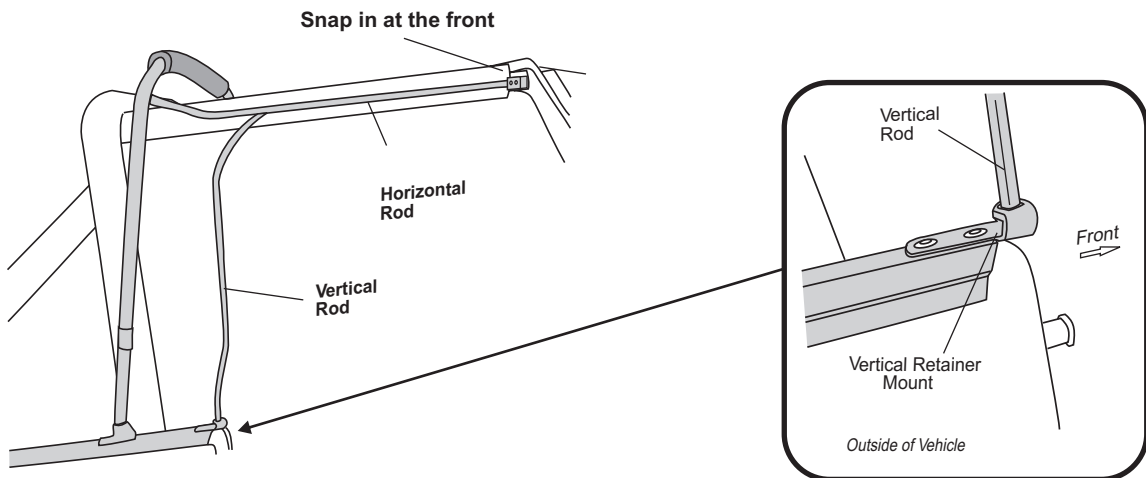

## Fabric Replacement Top Installation Instructions

1. Locate Top and remove rear quarter windows from top. Once you remove the windows orient it on the vehicle.  
**NOTE:** Install the Top with the spreader bar lowered (remove pin, lower Spreader Bar), front support bow all the way forward and rear support bow slightly forward to install the corners.
2. Snap the Top to the center and rear Bow Assemblies.

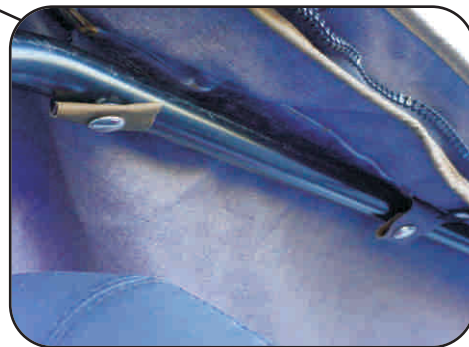
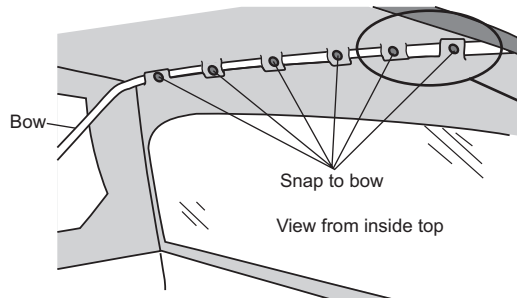

3. Insert the front of the top into the Windshield Channel.

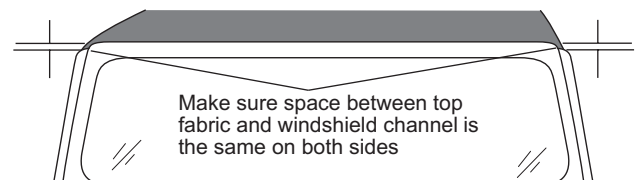
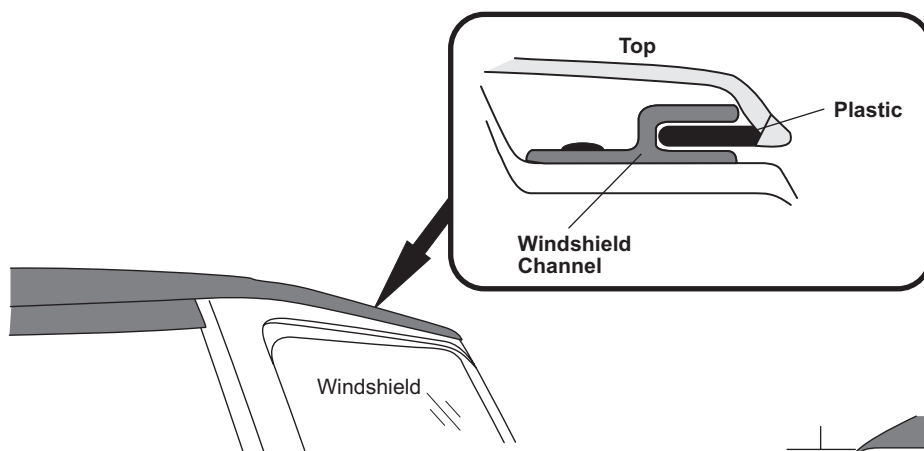



4. Insert rear corners of top into rear Corner Belt Rail.  
**NOTE:** Make sure the plastic reinforcement is not caught under Corner Belt Rail.
5. Pull the bottom of the rear support bow back until it snaps into the notch in the Side Belt Rail. **NOTE:** Bow must slip into notch in Side Belt Rail.
6. Push the Spreader Bars up until they snap into place.



7. Start horizontal and vertical zippers on the Quarter Window about 4-6 inches (Figure 7).
8. Insert the plastic strip on the front of the Quarter Window into channel on the front support bow (Figure 7).
9. Insert the plastic strip on the bottom of the Quarter Window into the Side Belt Rail (Figure 7). **NOTE:** Start at one end of the strip and work along it to the other end. Close the horizontal and vertical zippers on the quarter Window. Repeat this step for opposite side.

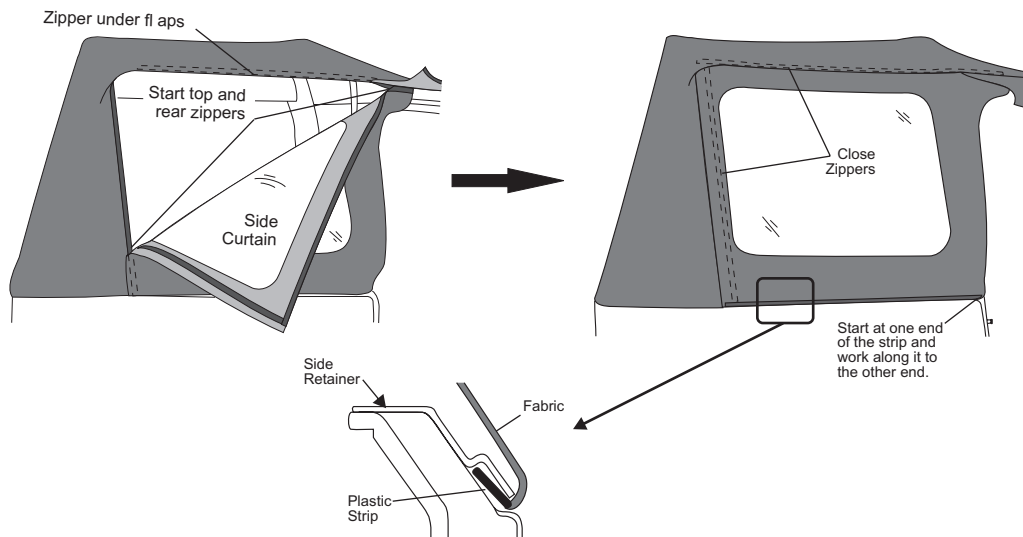

10. Open tailgate and attach rear window to top by closing the upper zipper only. Locate Tailgate Bar and Rear Tonneau Cover. Slide extrusion on the Tonneau Cover into Tailgate Bar



- 11. Once the Rear Seat Tonneau Cover is attached to Tailgate Bar, slide it into Rear Window extrusion located on the bottom of the rear window.
- 12. Close the Rear Window zippers.
- 13. Push the Tailgate Bar into the top of the Tailgate Brackets.



14. Insert the two flaps at the rear window into the rear corner channels on both sides of the tailgate as shown below.

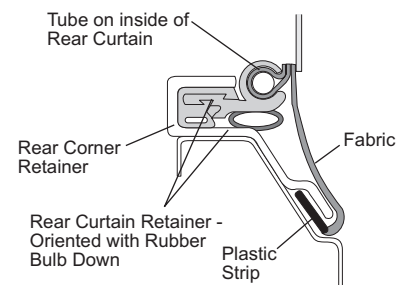
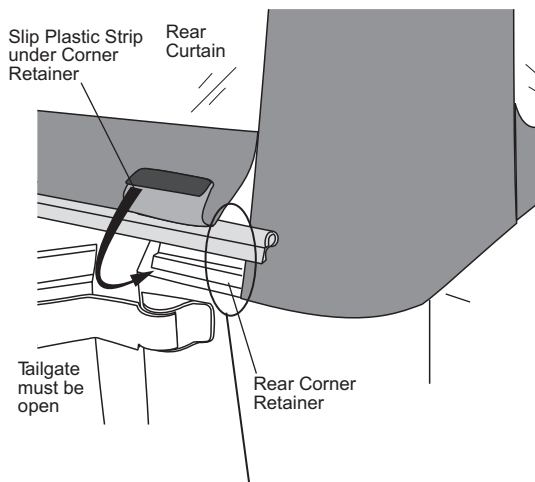



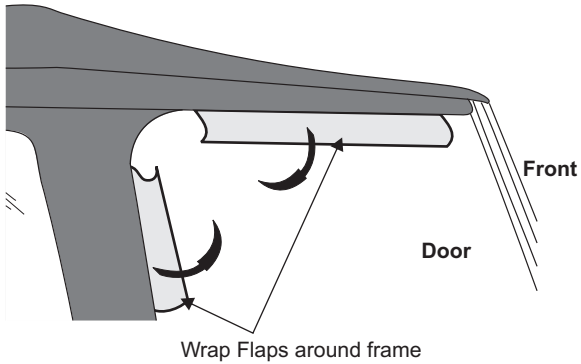

15. Wrap the door flaps around the door surrounds and attach back on the inside of the top with the velcro. Repeat for other side.

### Tailgate Tonneau Installation

1. Fold seat forward and position the Rear Seat Tonneau Cover. Use the hole on the strap as a guide to mark the hole on the fender.
2. Place strap aside and drill a 1/8" hole on the just marked locations. **NOTE:** Carefully check under drilling area to be sure you do not drill into any concealed wiring.
3. Re-position Rear Seat Tonneau Cover and attach both sides to the just drilled holes by using the included (2) - #8 x 1" Sheet Metal Screws.

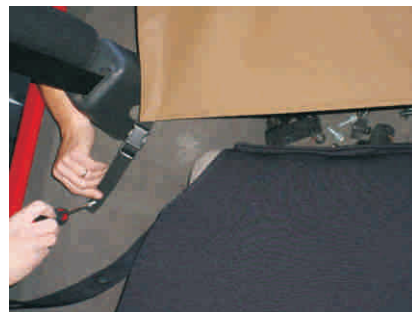

4. Locate Weather Strip and attach it to tailgate by inserting tailgate into the channel on the Weather Strip. **NOTE:** Make sure the Weather Strip is fully engage before closing the tailgate.



## **Important Care Instructions:**

Convertible tops and accessories require special care if you want to get the maximum usage and enjoyment from them. The following recommendations, if followed carefully, can extend the life of your top or accessory.

Hand wash using a mild non-detergent soap such as ivory. Use a non-abrasive cloth or sponge. Rinse thoroughly.

Do not wash in direct sunlight and avoid automatic car washes

When your top is clean, we recommend using “Ragg Topp” or “303 Protectant” on both the vinyl top and windows.

This product contains a sunscreen that helps protect from the sun’s damaging rays. Stay away from products containing alcohol, as it will cause the fabric and windows to lose their elasticity, thus reducing the life of your top or accessory. If you are unable to locate “RaggTopp” Please call 1-800-377-4700 for a distributor near you. For “303 Protectant”, please call 1-800-223-4303 for a distributor near you.

Direct sunlight and heat are the biggest enemies of the windows. Park in the shade whenever possible. If you must park in the sunlight, rotate the direction that you park every few days so all windows get even exposure.

Our tops are designed so that you may roll up and/or store the rear curtain and side curtains. To prevent scratching of the windows, be sure that windows are completely clean and free of dust particles. Even a little dirt will badly scratch the windows. You may want to use a soft cloth when rolling up or storing your windows. Heat may build up on rolled up windows, so be sure to unroll them frequently. If you roll up the windows at the beginning of summer and leave them, they may be ruined by fall.

Do not open or roll up windows at temperatures below 45 degrees F this could cause them to crack or break.

### **Zipper Care.**

DO NOT use pliers or other tools to pull on zippers. If the zipper requires more force than pulling with your fingers something is most likely out of alignment or improperly installed. Be sure the top is up to a temperature of 70 deg., and that the components are installed correctly and in the correct sequence to ensure protection of the zipper.

Zippers require periodic cleaning and lubrication to ensure longevity and ease of use. Clean by wiping with a towel soaked in soap and water, DO NOT USE HARSH CHEMICALS. Zipper lubricants are available at sporting goods stores and online for wetsuits. An occasional use will keep the zipper slides operating as new.

## **Warranty Information**

Rampage products, Inc. warrants to the original purchaser of any top it manufactures, that the top will be free of defects in material or workmanship for a period of 2 year from date of purchase. Such obligations under this warranty shall be limited to the repair or replacement, at Rampage products discretion, of any assembly or parts which, upon examination by Rampage products, Inc. proves to be defective. All defective items must be returned with proof of purchase to Rampage products, Inc., freight prepaid. This warranty does not cover damage resulting from abuse, misuse, alteration, accident or damage in transit. Rampage products obligations under this warranty are limited to the aforementioned repair or replacement of warranty defects for which the return authorization has been received during the warranty period, and Rampage products, Inc. shall not be liable for any incidental or consequential damages arising from breach of this or any implied warranty.

**Rampage Products 9225 Stellar Ct. Ste “C”, Corona, CA 92883 Phone: (951) 277-4949 Fax: (951) 277-2295**

**[www.rampageproducts.net](http://www.rampageproducts.net)**

*Made in China*