

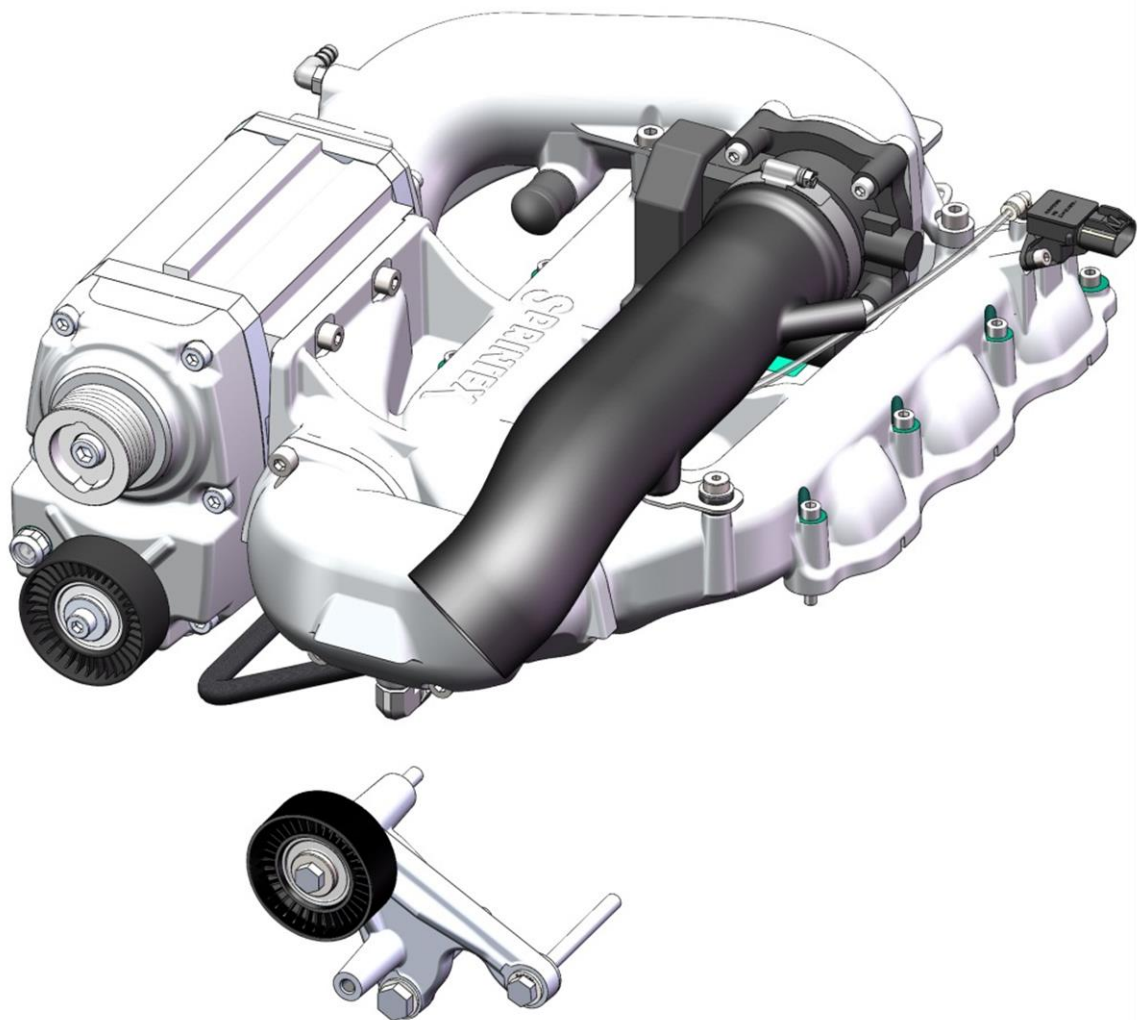

2007-2011 JEEP JK NON-INTERCOOLED SUPERCHARGER SYSTEM

TO SUIT 3.8L V6



INSTALLATION INSTRUCTIONS 251D1003

TABLE OF CONTENTS

INTELLECTUAL PROPERTY USED IN THIS PUBLICATION	- 4 -
IMPORTANT INFORMATION / PRODUCT WARNING	- 5 -
CHANGES TO FACTORY SPECIFICATIONS	- 7 -
TOOLS AND CONSUMABLES REQUIRED TO COMPLETE INSTALLATION	- 7 -
PARTS SUPPLIED	- 8 -
SECTION 1	- 12 -
DISASSEMBLY INSTRUCTIONS	- 12 -
1. DISCONNECT BATTERY	- 14 -
2. LOOSEN FUEL FILLER CAP	- 14 -
3. REMOVE AIR INLET PIPE	- 14 -
4. REMOVE AIR BOX	- 14 -
5. REMOVE CHARCOAL CANISTER VACUUM HOSE	- 15 -
6. DISCONNECT FUEL LINE	- 15 -
7. (OPTIONAL) REMOVE RIGHT SIDE INNER WHEEL WELL. (LHD). VEHICLES)	- 15 -
8. REMOVE EGR LINE	- 16 -
9. DISCONNECT MAP SENSOR	- 16 -
10. DISCONNECT THROTTLE BODY PLUG+	- 17 -
11. REMOVE VALVE COVER BREATHER HOSES	- 17 -
12. REMOVE INTAKE MANIFOLD	- 18 -
13. INTAKE RUNNERS	- 19 -
14. DISCONNECT INJECTOR PLUGS	- 19 -
15. REMOVE HARNESS FROM FUEL RAIL	- 19 -
MODIFYING HARNESS	- 20 -
16. STRIP BACK HARNESS	- 20 -
17. RE-ATTACH CONDUIT TO HARNESS	- 20 -
REPLACE INJECTORS	- 20 -
18. REMOVE FUEL RAIL	- 20 -
19. REMOVE INJECTORS	- 21 -
20. INSTALL NEW INJECTORS	- 21 -
21. INSTALL FUEL RAIL ASSEMBLY	- 21 -
22. ATTACH WIRING HARNESS	- 21 -
ALTERNATE VALVE COVERS	- 21 -
23. REMOVE ALTERNATOR WIRING CLIPS	- 21 -

24. REMOVE ALTERNATOR BRACE	- 22 -
25. REMOVE COIL PACK	- 22 -
26. REMOVE COIL PACK BRACKET	- 22 -
27. REMOVE ALTERNATOR	- 23 -
28. ALTERNATE VALVE COVERS	- 23 -
29. FIT COIL PACK BRACKET	- 23 -
30. FIT ALTERNATOR BRACE	- 24 -
31. ROTATE HOSE CLAMP	- 24 -
32. REMOVE SECTION OF FUEL LINE	- 25 -
33. (L.H.D.VEHICLES) TRIMMING BATTERY BOX	- 26 -
INSTALLATION INSTRUCTIONS	- 27 -
1. INSTALL FUEL LINE	- 28 -
3. IDLER BRACKET INSTALLATION	- 30 -
FITTING SUPERCHARGER MANIFOLD	- 31 -
4. INSTALL EGR PLATE	- 31 -
5. REPLACE SEALS	- 31 -
6. FIT HOSE SUPPORT BRACKET	- 31 -
7. REMOVE THE OUTLET DUCT.	- 32 -
8. FITTING MANIFOLD	- 32 -
9. FITTING THROTTLE BODY	- 33 -
10. INSTALL OUTLET DUCT	- 33 -
11. INSTALL DRIVE BELT	- 34 -
12. FIT BREATHER HOSES	- 34 -
13. FIT THE THROTTLE BODY INTAKE ASSEMBLY	- 35 -
14. INSTALL AIR BOX	- 35 -
15. CONNECT INLET PIPE	- 35 -
16. INSTALL CANISTER VACUUM HOSE	- 35 -
17. RECONNECT BATTERY	- 36 -
18. LOAD THE ECM RE-FLASH.	- 36 -
19. INSTALL PREMIUM UNLEADED FUEL STICKER	- 36 -
PRE TEST-DRIVE INSPECTION	- 37 -
MAINTENANCE INSTRUCTIONS	- 39 -

INTELLECTUAL PROPERTY USED IN THIS PUBLICATION

This document is copyright of Sprintex Ltd, a company incorporated in Australia. This document may not be re-sold, copied or distributed in any way without prior written authorisation of Sprintex Ltd.

Copyrights / Trademarks:

Sprintex® is a registered trademark of Sprintex Limited, an Australian company ACN: 106 337 599 (“Sprintex”). Sprintex has patents for its superchargers. Any unauthorised copying or modification of the system may result in legal action.

Loctite® and Grey Maxx® are registered trademarks of Henkel KGaA, a company incorporated in Germany. Other than commercial supply arrangements, Henkel KGaA does not have any association with Sprintex.

RedLine® is a registered trademark of RedLine Synthetic Oil Corporation, a company incorporated in the United States of America. Other than commercial supply arrangements, Redline and RedLine Synthetic Oil Corporation do not have any association with Sprintex.

Castrol, the Castrol logo and related marks are trademarks of Castrol Limited, used under licence. Castrol Limited does not have any association with Sprintex.

Lucas synthetic SAE 75W-90 gear oil is a product of Lucas Oil Products, Inc. 302 North Sheridan St. Corona, CA 92880 - 800.342.2512. Lucas Oil Products, Inc. does not have any association with Sprintex.

Jeep, Jeep JK, Jeep Wrangler are registered trademarks of FCA US LLC, formerly Chrysler Group LLC. A company Headquartered in Auburn Hills, MI, USA.
(www.fcausllc.com)

SAE is a trademark of SAE International (www.sae.org) an international technology, information and standards setting resource organisation for the design, manufacturing, operation, and maintenance industry.

Gates is a registered trademark of the Gates Rubber Company, a subsidiary of Tomkins PLC, incorporated in London, United Kingdom. Other than commercial supply arrangements, Gates and Tomkins PLC do not have any association with Sprintex Limited.

IMPORTANT INFORMATION / PRODUCT WARNING

Installation of the Sprintex Supercharger system on a 3.8L V6 Jeep - JK vehicle may void all or parts of the Jeep Warranty. Customers should consult their Jeep dealer for details.

Sprintex makes no representation that installation and use of the Sprintex supercharger system is legal for public road use worldwide. Customers should check that installation and use of the Sprintex supercharger system on their vehicle is legal by contacting the relevant statutory authority in their jurisdiction prior to use on public roads.

Provided in this installation manual are detailed instructions to the installer on how to install the Sprintex patent pending supercharger system to the Jeep- JK vehicle. The instructions are aimed at being simple yet informative, and are aided with well-presented pictures to make installations as simple, fast, and problem free as possible. Please read the entire instruction manual prior to beginning the installation procedure. Pictures and descriptions may vary slightly from model to model.

It is recommended that all wiring harness connectors, and vacuum hoses are labelled at the time of removal for easy and correct refitting. Some components that are removed and are to be refitted are fragile, and should be stored safely to prevent damage to these components.

- Sprintex recommends performing the following vehicle checks prior to installing the supercharger:
- Check that the factory fuel system is operating correctly.
- Ensure that the vehicles ignition system is working correctly.
- Install new standard spark plugs and set gap to 0.043" / 1.1mm.
- Inspect the catalytic converters for blocks or damage.
- Replace the fuel filter if the vehicle has travelled more than 15,000 Km or 9000 miles.

It is recommended to run at least one full tank of premium unleaded fuel through the vehicle prior to installing the supercharger system to prevent any possible damage that may occur due to running the supercharged engine on lower octane fuel.

Sprintex will not be liable for any loss, damage, payment, costs, expenses or other liability, not expressly stated in this document. In particular, Sprintex shall not be liable to any person for any consequential, indirect or economic loss or punitive or exemplary damages of any kind.

Sprintex reserves the right to change specifications from time to time and will not be liable to any person or entity for doing so. Sprintex believes that information in this document is correct at time of print. Sprintex limits its liability to the maximum extent permissible at law with regard to the reliance which any person places on anything in this document.

This Sprintex installation requires that the vehicle be equipped with a standard Jeep-JK factory ECU and calibration. Failure to ensure this will affect the performance and may void warranty.

California residents:

California Proposition 65 entitles California to special warnings for products that contain chemicals known to the state of California to cause cancer and birth defects or other reproductive harm.



WARNING

This product can expose you to chemicals including Cumene, which is known to the State of California to cause cancer or birth defects or other reproductive harm.

For more information, visit

www.P65Warnings.ca.gov.

CHANGES TO FACTORY SPECIFICATIONS

FUEL: Minimum 95 RON (91 Octane USA) premium unleaded gasoline / fuel to be used at all times. Never allow the engine to knock or detonate as serious engine damage may occur.

SERVICING REQUIREMENTS: See maintenance section of this manual.

Inspect supercharger drive belt at every routine service and replace when required.

Drain and replace supercharger oil every 50,000 km or 30,000 miles. Use a quality fully synthetic SAE 75W-90 gear oil, specifications: API GL5, MT1 such as: Redline 75W90 NS gear oil (factory fill), Castrol Syntrax Universal Plus 75W-90, Lucas synthetic SAE 75W-90 gear oil or equivalent. It is critical not to overfill supercharger gearbox as,

- a. damage might occur or
- b. rapid oil loss in the supercharger might be experienced until the oil reaches the recommended level.

Fill with exactly 100 millilitres or 3.38 US fluid ounces and check the oil level with the dipstick provided.

NOTE:

Many of the photos shown in this document are of a typical Jeep-JK right hand drive vehicle and are similar to a typical Jeep-JK left hand drive vehicle.

Some of the terminology and language used in this instruction may vary from that of the end user / installer's expectations, as some tools and automotive components have different common names in different geographical locations.

TOOLS AND CONSUMABLES REQUIRED TO COMPLETE INSTALLATION

- Set Metric & Inch Wrenches and Sockets
- Metric Allen keys
- 3/8" or 1/4" Universal Joint
- Torque Wrench
- Pliers and Side Cutters (Dykes)
- Flat and Philips Screwdrivers
- Pipe sealer, sealant, thread locker, rubber grease or silicone spray
- Ear clamp crimp pliers
- 3/8" Breaker Bar
- Electrical Tape

PARTS SUPPLIED

Sprintex® supercharger manifold assembly

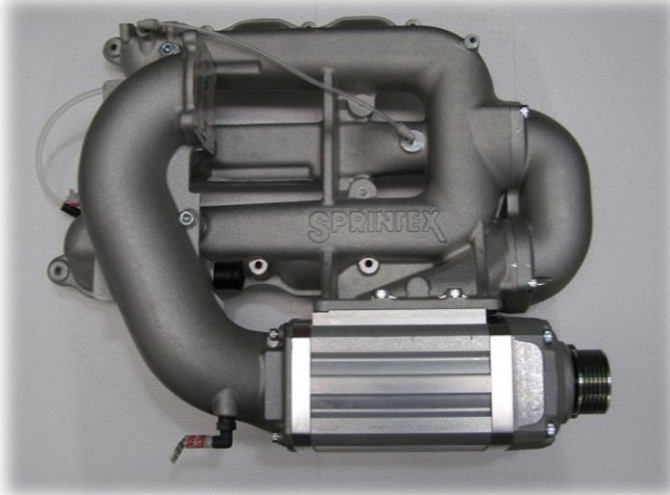

Additional idler bracket



Inlet air duct



Replacement fuel supply and EVAP hoses



EGR pipe and mounting adaptor



Ancillary parts



Replacement fuel injectors



Diablo ECM Re-flash unit



Engine breather hose



Rubber joiner elbow



Sticker - Premium Unleaded Fuel



- Sprintex® supercharger manifold assembly
- Throttle body intake assembly
- Fuel feed hose & canister vacuum hose
- Installation manual
- Engine breather hose
- Rubber joiner elbows (x 2)
- Idler pulley bracket assembly
- Fuel injectors (x 6)
- EGR plate assembly
- Diablo ECU reflash unit
- Ancillary parts

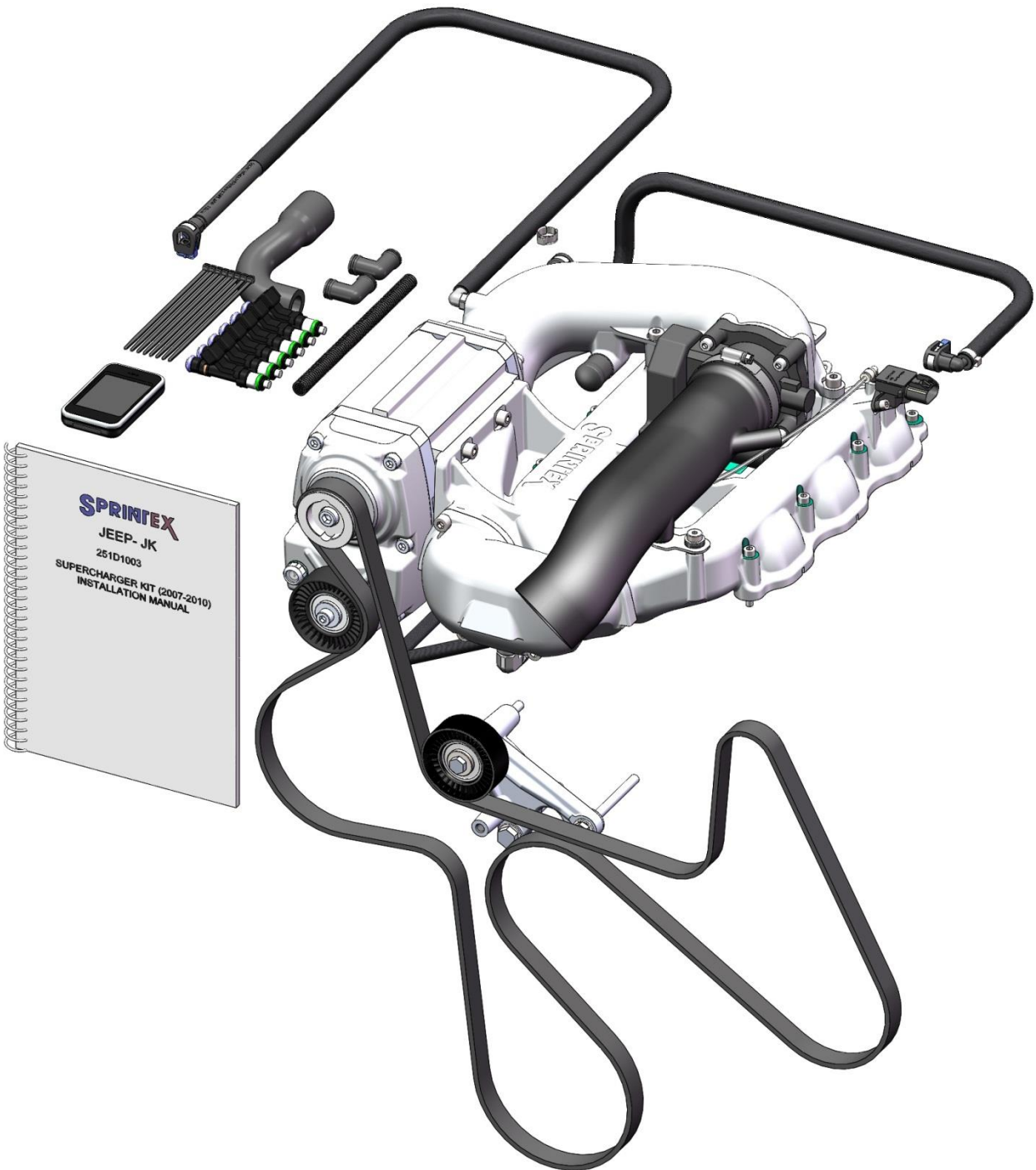

3.8L V6 JEEP-JK NON-INTERCOOLED SUPERCHARGER SYSTEM

SECTION 1

DISASSEMBLY INSTRUCTIONS

PREPARATION

Ensure that all components required to install the supercharger system are available, refer to the Parts Supplied section provided earlier.

Ensure that all required tools are available.

Please read the entire installation manual prior to beginning the installation procedure.

Ensure the vehicle is located in a secure position with vehicle tyres secured and hand brake applied. To avoid injury, Sprintex® recommends the use of a suitable vehicle lift or appropriate safety stands when the vehicle is required to be lifted. Stands should be positioned as per the vehicle manufacturer's owner's handbook.

SAFETY WARNING

No unauthorised service or alteration may be undertaken to the Sprintex supercharger. Installation should be carried out in a workshop which is a safe and ventilated working environment with equipment and procedures compliant with local authority guidelines and legal requirements.

Installers should ensure adequate hearing, eye, and physical protection is used at all times during the installation process. Installers should take reasonable precautions to avoid fatigue and closely follow the installation instructions during every installation. Sprintex recommends installation should not be carried out unsupervised. Sprintex, its directors, employees and agents will not accept liability for damage accident or injury resulting from the installation process. Safety warnings are also provided throughout this document.

Allow engine to cool prior to proceeding with disassembly to prevent scalding.

NOTES:

- During disassembly and removal of components, take notes and ensure parts are labelled and stored safely; this will help with the reassembly.
- Many of the photos shown in this document are of a typical Jeep- JK right hand drive vehicle and are similar to a typical Jeep- JK left hand drive vehicle.



Left hand drive vehicle



Right hand drive vehicle

- Connect and disconnect battery cables, jumper cables or battery charger only with the ignition off.
- Disconnecting the battery may erase fault codes stored in control module memory. Using diagnostic equipment, check for fault codes before disconnecting battery cables. If the malfunction indicator light (MIL) is illuminated.
- **MIL (Malfunction Indicator Lamp) light.**
The MIL light can be found in one of two locations, dependant on the market the vehicle has been built for.
The MIL light may be an illuminated ENGINE symbol within the instrument cluster. Please refer to the Jeep owner's handbook to define which off the above applies to the vehicle to be fitted with the Sprintex unit.
- Always disconnect the negative battery terminal first. This prevents possible shorting and potential battery damage.

1. Disconnect Battery

- First disconnect negative (-) battery cable.
- Then disconnect positive (+) cable.
- Remove battery completely for LHD vehicles to allow better access when modifying battery box.

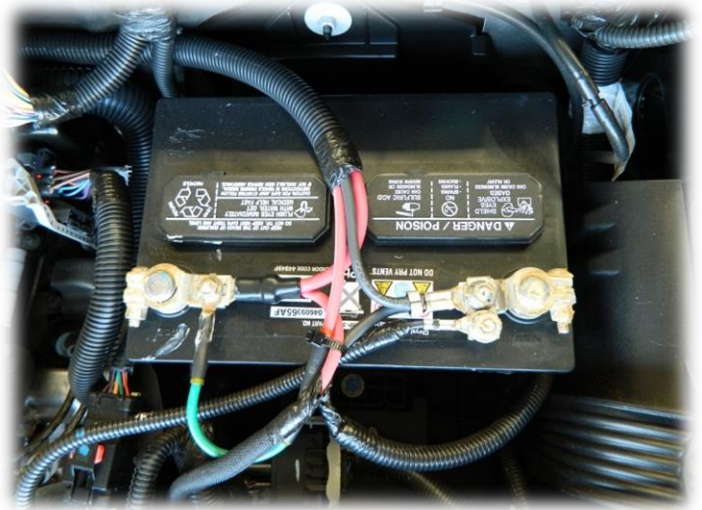

2. Loosen fuel filler cap

- Loosen fuel filler cap to relieve pressure in the system.



3. Remove air inlet pipe

- Disconnect air temp. sensor
- Loosen the 2 hose clamps with a flat blade screw driver and remove the air inlet pipe.



4. Remove air box

- Disconnect breather hose from valve cover.
- Remove air box and breather hose and set aside.

5. Remove charcoal canister vacuum hose

- Disconnect hose and fitting from the canister, disconnect other end of hose from the manifold and remove hose from the vehicle.
- Remove hose clamp from hose set.

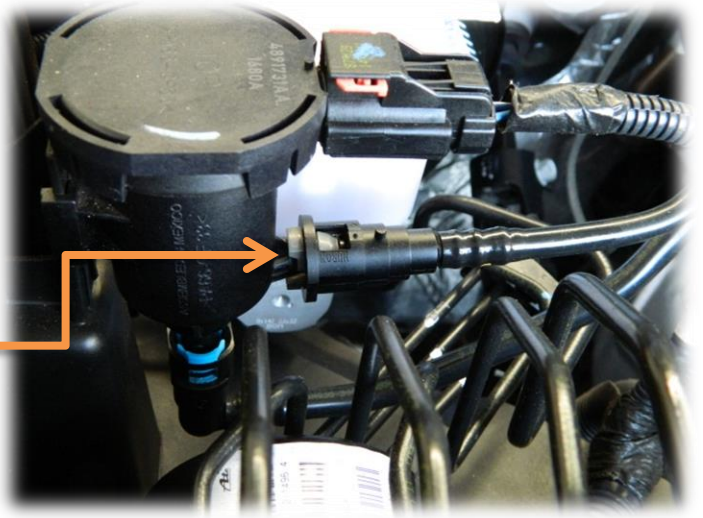

6. Disconnect fuel line

- Place a rag under the fuel fitting and disconnect fuel fitting from fuel rail.
- A fuel fitting disconnect tool maybe required to remove the fuel line.



7. (Optional) Remove right side inner wheel well. (LHD). VEHICLES)

- To assist access to EGR valve it may be beneficial to remove the right side wheel and inner wheel well, (LHD VEHICLES ONLY) this step is not necessary but does make fitting components easier.

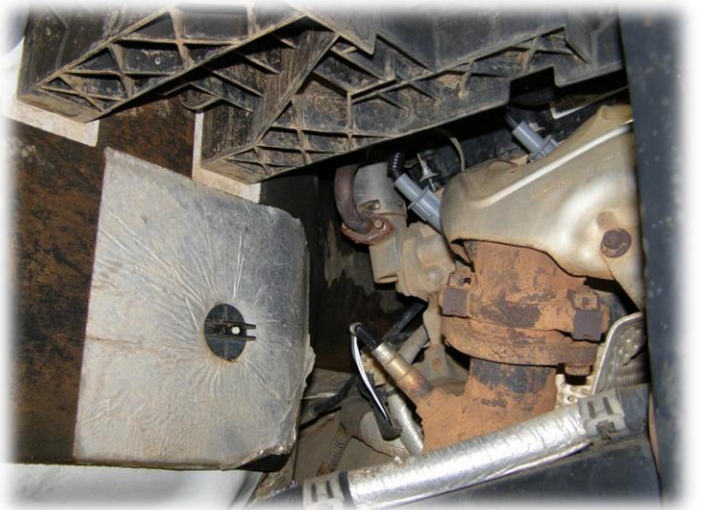

8. Remove EGR Line

- Remove the 2 screws from the EGR valve (8mm socket or spanner).
- Remove the 2 black screws from the top of the manifold (8mm socket or spanner).
- Remove 13mm nut from stud and remove EGR tube from engine.



9. Disconnect MAP sensor

- Pull lock tab back on plug before removing plug connector from sensor.



10. Disconnect throttle body plug+

- Depress 2 lock tabs on the top and bottom of plug before removing plug connector.



11. Remove valve cover breather hoses

- Loosen hose clamps on each end of hose and remove breather hose. This hose is not re-used in the supercharger system.
- Disconnect plug leads if needed for better access.

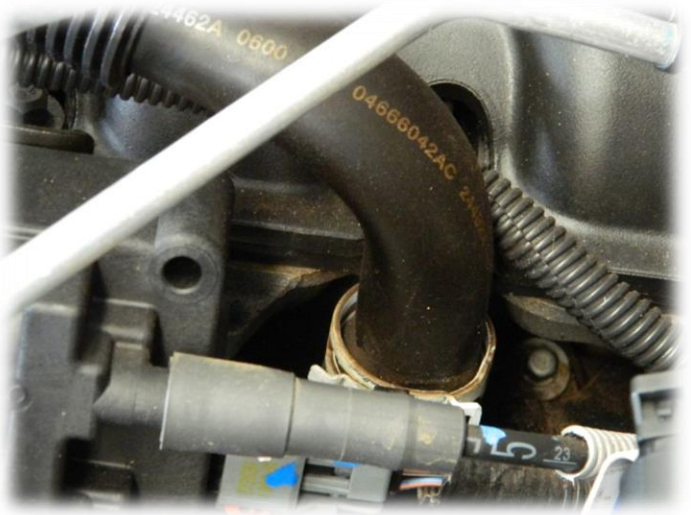

12. Remove intake manifold

- Remove the 8 black manifold screws (10mm socket or spanner) gently remove the plastic manifold from the cast aluminium intake runners and disconnect the brake booster hose in the process.



BRAKE BOOSTER HOSE

13. Intake runners

- Tape up or cover intake runners to prevent foreign objects falling down the intake runners.



14. Disconnect injector plugs

- Lift the red lock tab up first before pressing tab to remove the injector plug connector.

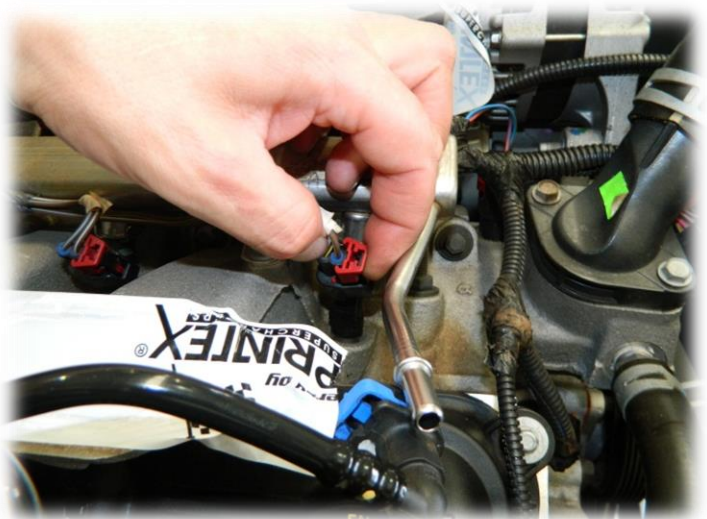

15. Remove harness from fuel rail

- Carefully remove fuel rail harness from the fuel rail assembly by gently prying up harness cable ties.

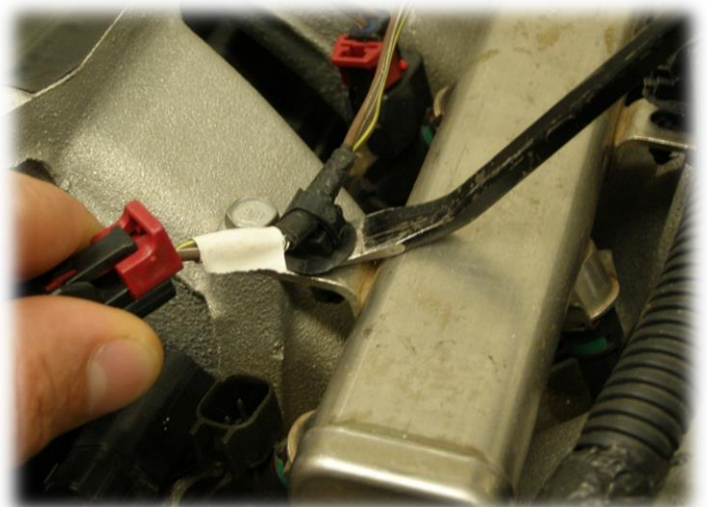

MODIFYING HARNESS

16. Strip back harness

- Carefully strip back harness 6 inches to separate throttle body cables and plug from main harness.

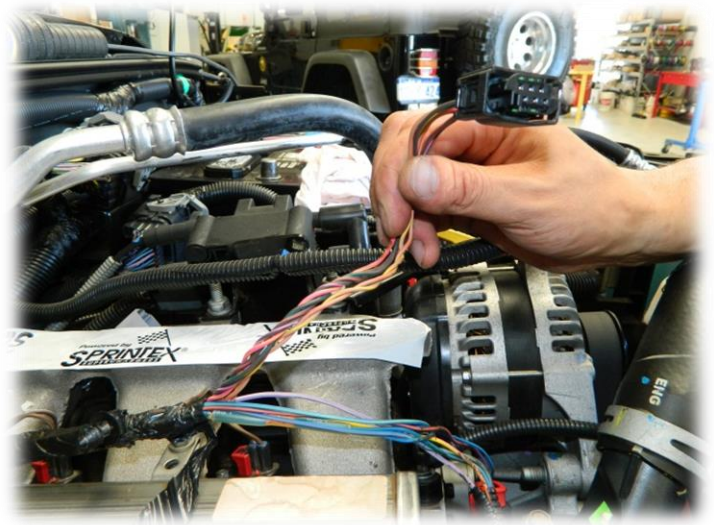

17. Re-attach conduit to harness

- Re-attach conduit to main group of cables, fit the supplied conduit to the throttle body cables and neatly retape the harness.



REPLACE INJECTORS

18. Remove fuel rail

- Gently blow air around injectors to remove any loose dirt that may fall into the engine when the injectors are removed.
- Remove 4 screws (10mm socket or spanner), gently lift fuel rail assembly out.



19. Remove injectors

- Remove one injector first and drain residual fuel from rail.
- Remove the injector retaining clips from fuel rail assembly and set them aside.
- Remove the injectors from the fuel rail, make note of the injectors orientation.

20. Install new injectors

- Install the 6 new injectors supplied with the system into fuel rail, apply a small amount of rubber grease or silicone spray to o-rings to prevent damaging them during installation.
- Once the injectors are in place refit the retaining clips.

21. Install fuel rail assembly

- Apply a small amount of rubber grease or silicone spray to o-rings prior to installing the fuel rail assembly, rotate the assembly 180° from its original position, so that the fuel feed is toward the rear of the engine, install the fuel rail and tighten with the 4 screws.



22. Attach wiring harness

- Reconnect the wiring harness to fuel rail.

ALTERNATE VALVE COVERS

23. Remove alternator wiring clips

- Remove alternator harness from brace and coil pack bracket.



24. Remove alternator brace

- Remove bolt and nut from brace using a 13mm spanner or socket.

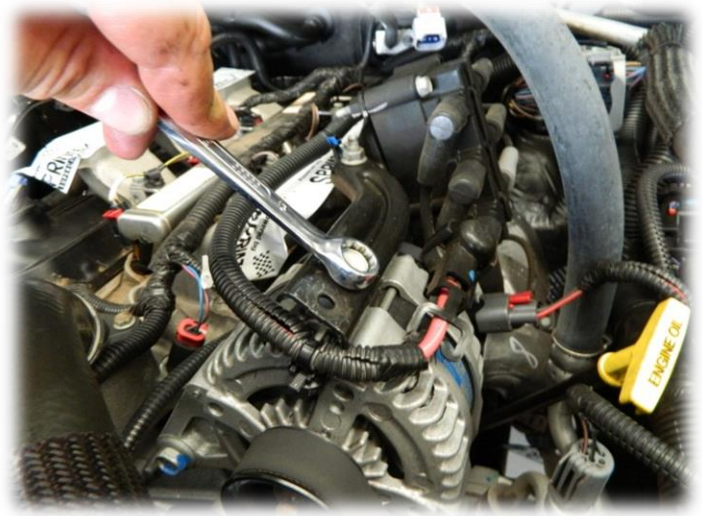

25. Remove coil pack

- Remove 2 screws on coil pack (10mm socket) and lower coil pack out of the way.

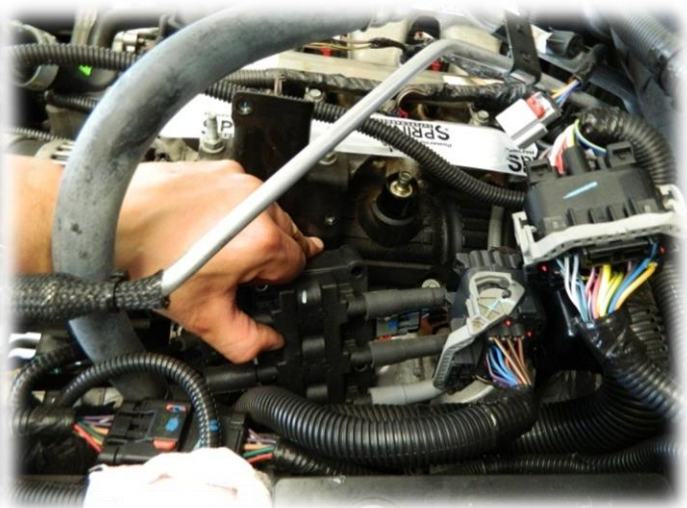
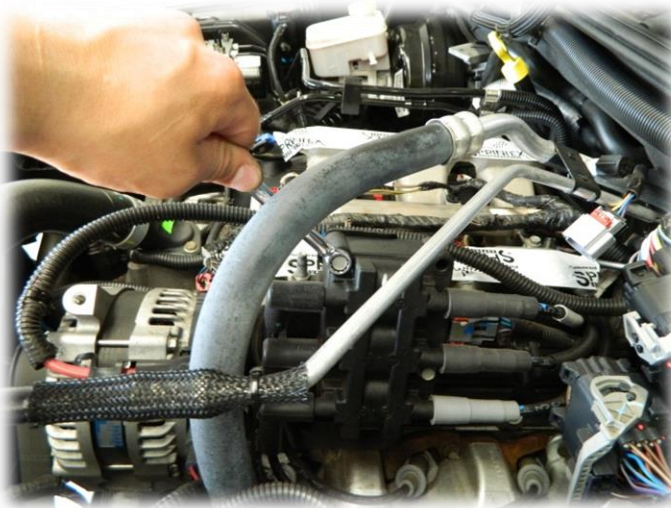

26. Remove coil pack bracket

- Remove the 2 studs and 2 nuts that retain the bracket (13mm socket or spanner) and then remove the bracket.

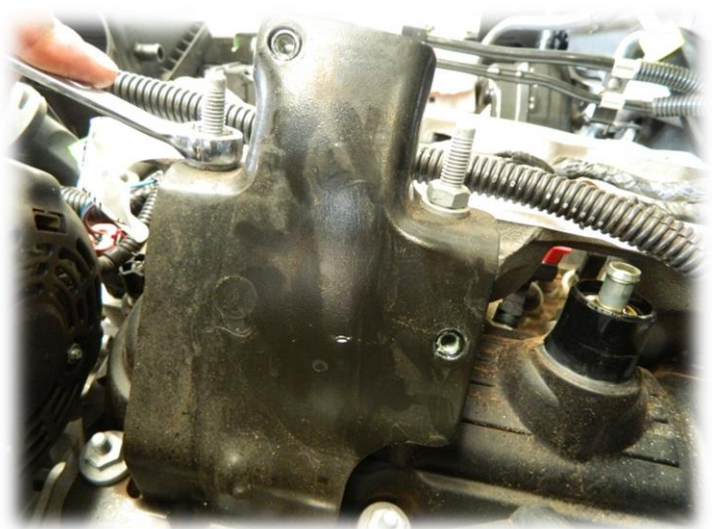

27. Remove alternator

- Disconnect alternator plug and lead.
- Remove 2 bolts from front of alternator with a 16mm socket or spanner and remove alternator from vehicle.

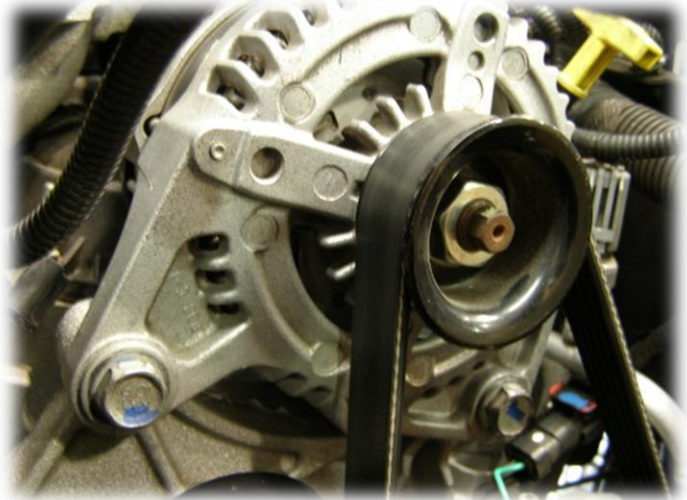
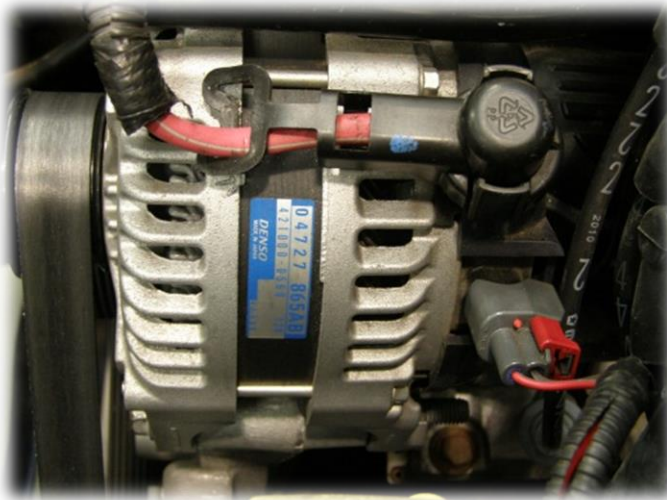

28. Alternate valve covers

- Remove plug lead cradle from valve cover.
- Remove clamp from heater hoses and set aside to use later.
- Loosen all valve cover bolts and remove, alternate valve covers left to right.
- Tighten valve covers back in place.
- Re-attach plug lead cradle.
- Re-attach alternator.



29. Fit coil pack bracket

- Attach the coil pack bracket, when tightening bracket gently pull the bracket away from the centre to the engine, this is to provide better clearance when fitting supercharger manifold.

30. Fit alternator brace

- Re-attach alternator brace with its original fasteners



31. Rotate hose clamp

- Rotate hose clamp so that the clamp ears are facing the ground, this is done to provide better clearance for the supercharger outlet.

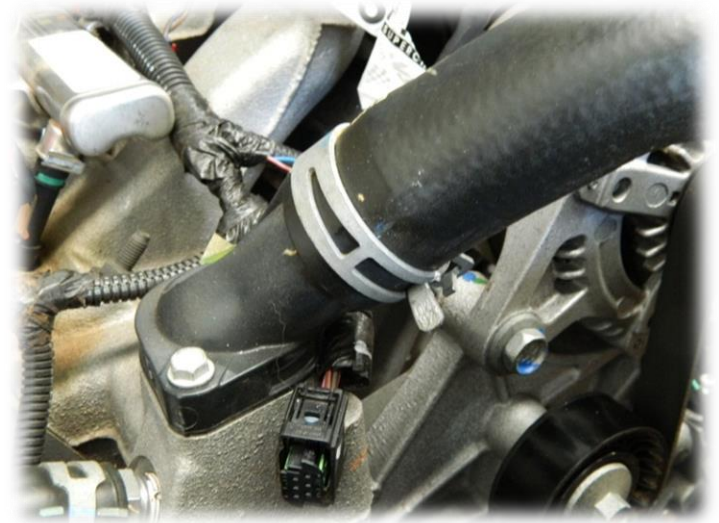

32. Remove section of fuel line

- Remove the last section of the fuel line, depending on the vehicle set up; this may require carefully slitting the hose with a sharp blade to expose the barb on the rigid fuel line.



- Take care slitting the hose to avoid scoring the fuel line with the sharp blade as this could cause a leak.

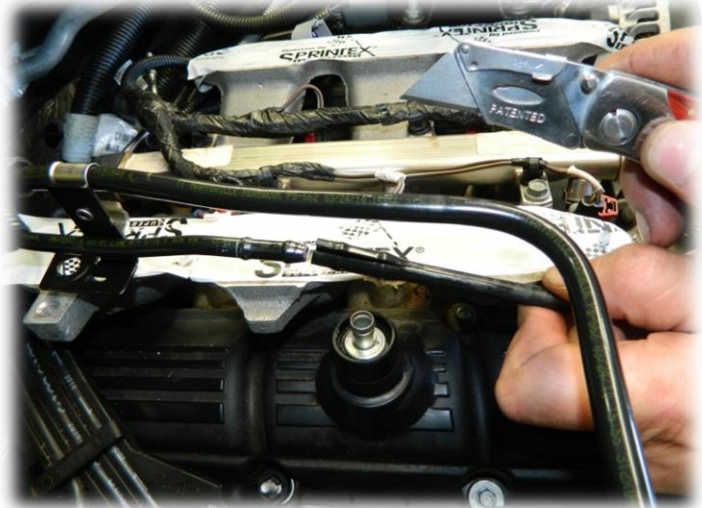

- Disconnect last section of fuel line with a fuel fitting removal tool.



33. (L.H.D.VEHICLES) Trimming battery box

- LHD vehicle only requires some trimming of the factory battery box, use the trimming template supplied in the fitting instructions.
- Cut out template supplied template, (last page of instruction manual) and stick template to battery box and cut along marked line.



3.8L V6 JEEP-JK NON-INTERCOOLED SUPERCHARGER SYSTEM

SECTION 2

INSTALLATION INSTRUCTIONS

INSTALL FUEL LINE AND PURGE LINE

1. Install fuel line

- Route the supplied fuel line (800mm long) as shown in picture, fix in place with cable ties supplied. Connect the fuel line & ensure it is securely fitted.
- In some instances (depending on the fuel system of the vehicle) it may be necessary to connect one end of the fuel line directly to the vehicles hard line using a hose clamp. If this is the case, cut off one end of the fuel line (including the fitting & hose clamp) and connect the fuel line to the vehicles hard line using the hose clamp supplied in the system.

IMPORTANT NOTE

ENSURE THAT THE FUEL LINE IS ATTACHED SECURELY TO THE FUEL FEED LINE. CRIMP SUPPLIED EAR CLAMP SECURELY (WHERE APPLICABLE) WITH THE CORRECT TOOL. CORRECT FITTING OF THE FUEL LINE IS CRITICAL TO SAFE OPERATION OF THE VEHICLE.

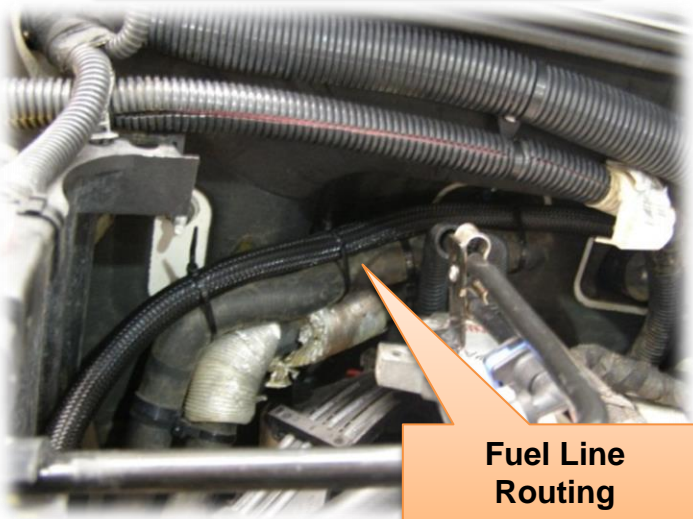

2. Modify purge line

- Cut purge line 6" inches from the inside of the bend in both directions.



- Fit the supplied rubber joiner elbows supplied to cut section of tube. Refit the cut section and elbows as shown below.



- (US VEHICLES) Drill a 3/4" hole into battery box to feed purge line through.



3. Idler bracket installation

- Loosen 3 x water pump pulley bolts (13mm spanner or socket).
- Remove the engine drive belt from the engine, use a 3/8" breaker bar to relieve tension on belt.

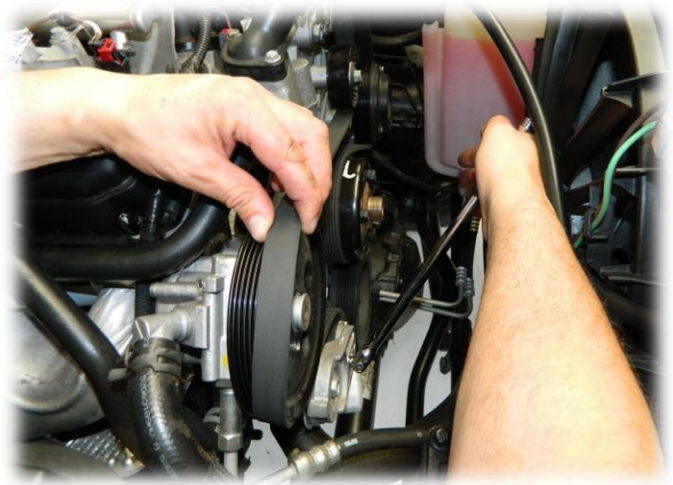

- Remove the water pump pulley.
- Remove 2 bolts from engine casing (see pic).

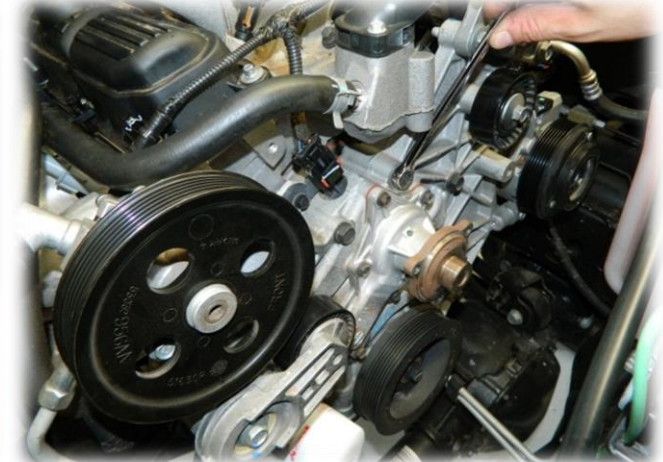

- Fit the tensioner assembly to the engine using the bolts supplied in system.
- Install the water pump pulley and tighten with 3 bolts.



FITTING SUPERCHARGER MANIFOLD

4. Install EGR plate

- Install EGR adaptor plate assembly to EGR valve, tighten with 2 x M6 x 25 SHCS supplied in system and tighten to 12Nm.
- Fit new EGR tube in place but do not tighten compression fittings.

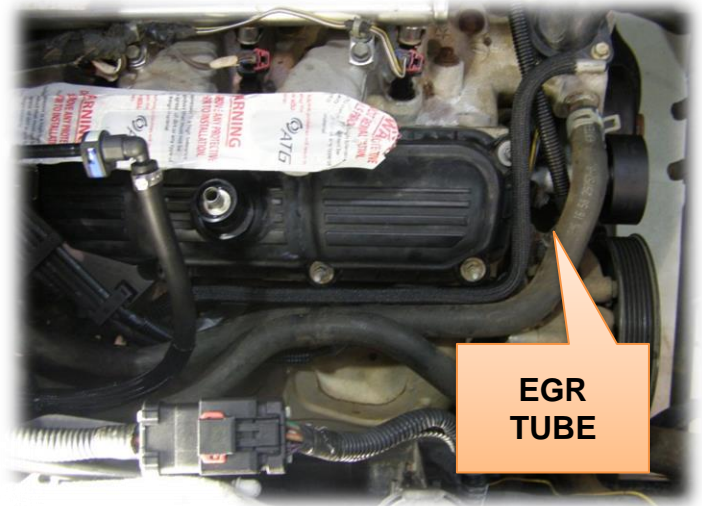

5. Replace seals

- Carefully remove manifold seals from plastic intake manifold and fit them into the supercharger manifold, (take care not to damage seals in the process).

6. Fit hose support bracket

- Remove the 2 screws from the bottom of the supercharger intake and attach the hose support bracket and tighten the 2 existing screws to 12Nm.

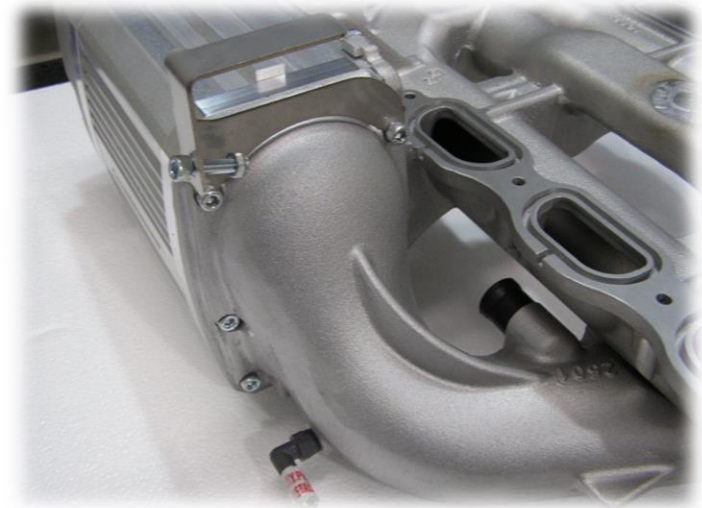

7. Remove the outlet duct.

- Remove the outlet duct from the supercharger assembly and rubber blanking cap to assist fitting.



8. Fitting manifold

- Remove tape or rags from intake runners prior to fitting manifold.
- Position throttle body plug so it can be accessed once manifold is in place.
- Gently rest the supercharger manifold onto the intake runners. **(2 person lift)**
- Attach the brake booster hose to the fitting on the back of the supercharger manifold assembly.
- Make sure that the seals are still in place before fixing the supercharger manifold in place with the screws supplied with the system.
- Make sure that throttle body plug connector is accessible at this stage.
- Secure manifold down with 5 x M6 x 50 SHCS and 3 x M6 x 30 SHCS tighten to 12Nm.
- Prior to installing the MAP sensor check the hole in the manifold for burrs and sharp edges and lubricate the MAP sensor O-ring with rubber grease or similar.
- Install MAP sensor and attach with 2 x M5 x 20 SHCS and tighten to 8Nm.
- Connect the wiring harness connector to the MAP sensor.
- **NOTE:** Ensure there is at least 25 mm (1 inch) clearance between MAP sensor and nearby air-conditioning pipework.

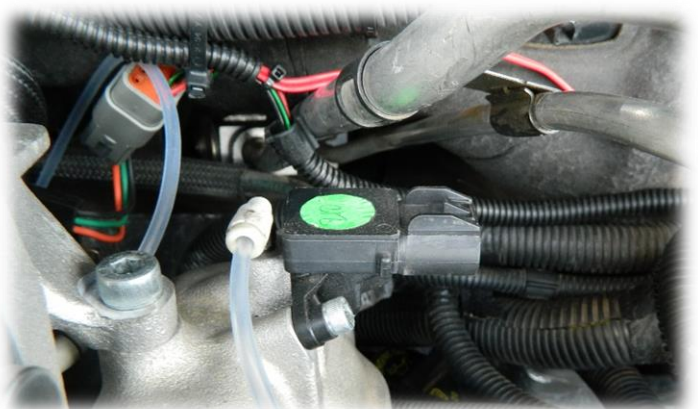

9. Fitting throttle body

- Remove throttle body from plastic intake manifold and fit to supercharger manifold with 4 x M6 x 40 SHCS supplied in system and tighten to 10Nm.
- Make sure to remove tape from supercharger intake prior to fitting throttle body and supplied o-ring is in place.
- Connect throttle plug connector to throttle body.

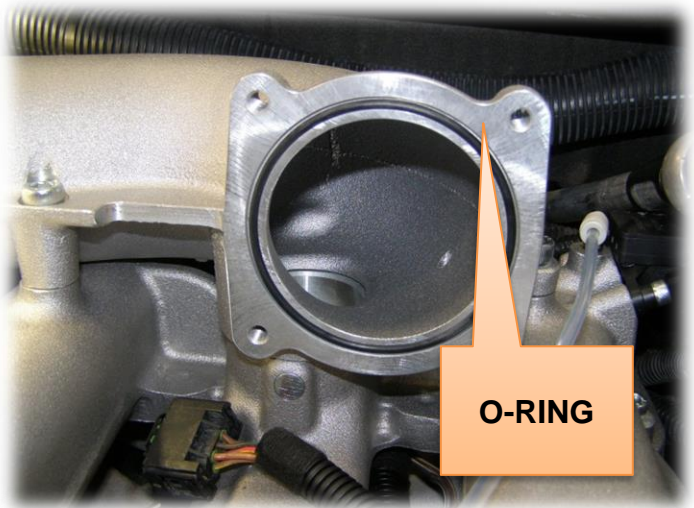

10. Install outlet duct

- Install the outlet duct to the supercharger manifold attach the EGR tube into the compression fitting during the process, tighten the 4 x M8 SHCS to 23Nm.
- Make sure tube is properly seated in the fittings and tighten compression fittings on both ends of EGR tube.
- Re-install hose clamp onto hose support bracket.

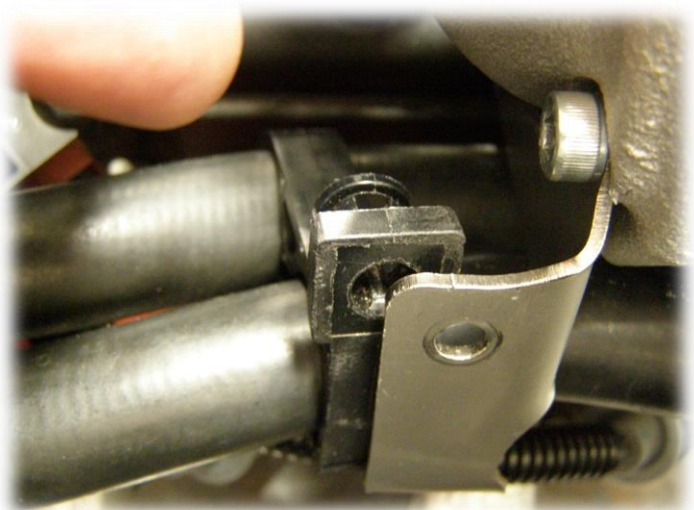
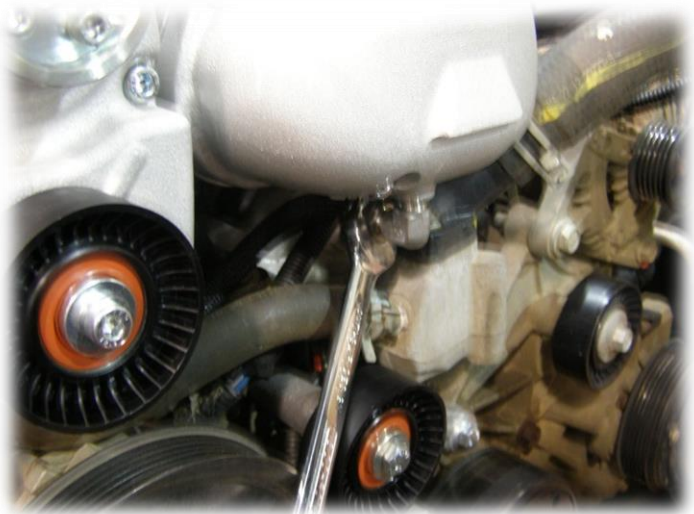

13. Fit the throttle body intake assembly

- Fit throttle body intake assembly to the manifold using the hose clamps and bolts supplied in the system.
- Connect fresh air inlet hose (from valve cover) to intake.

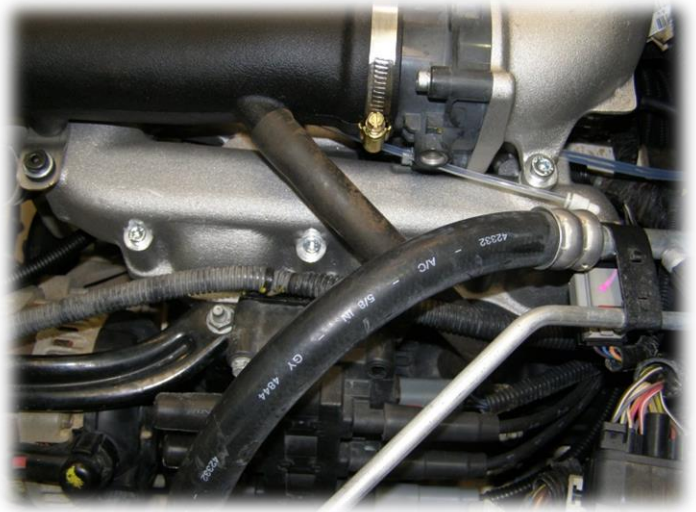

14. Install air box

- Fit the rubber blanking cap to the air box and refit the air box into the engine bay



15. Connect inlet pipe

- Connect air intake pipe to air box and throttle body intake with hose clamps.
- Connect air temp sensor.



16. Install canister vacuum hose

- Install new canister vacuum hose (1m long) supplied in system as shown in pictures.
- Attach open end of hose to fitting on the supercharger intake.
- Fix in place with cable ties supplied.

17. Reconnect battery

- Re-install battery if removed and connect terminals.
- **NOTE: Battery Positive terminal (B) should always be connected first.**



18. Load the ECM re-flash.

- Read the instructions included with the Diablo SP2000 flash tuner.
- Follow the instructions included with the Diablo SP2000 flash tuner.



19. Install Premium unleaded fuel sticker

- It is recommended that the Premium unleaded fuel sticker is installed inside of the fuel flap or close to the fuel cap in a visible convenient location.
- Clean the area with soap and water, rubbing alcohol or any other fast drying cleaner.
- Remove sticker from its plastic bag and peel sticker off front protective film and paper backing.
- Place sticker.



3.8L V6 JEEP-JK NON-INTERCOOLED SUPERCHARGER SYSTEM

SECTION 3

PRE TEST-DRIVE INSPECTION

1. Pre-Start Inspection.

- Ensure coolant is at correct level.
- Ensure engine oil is at correct level.
- Ensure vehicle has fresh 95 RON (91 Octane USA) premium unleaded fuel or higher.
- Ensure the belt is correctly installed on each pulley and aligned.
- Ensure the air filter is clean.
- Check & replace spark plugs if necessary.

SAFETY WARNING: Ensure adequate steps are taken to prevent injury, spillage or fire should any of the required installation steps not have been carried out to specification.

2. Engine Warm Up.

- Start engine and allow it to run until engine reaches normal operating temperature.
- Check for coolant leaks.
- Check engine coolant level and top up if required

3. Road Test Vehicle.

- Road test vehicle.
- Recheck all joints and connections for leaks and rectify as necessary.
- Check engine coolant level and top up as necessary

3.8L V6 JEEP- JK NON-INTERCOOLED SUPERCHARGER SYSTEM

SECTION 4

MAINTENANCE INSTRUCTIONS

1. Supercharger Drive Belt Replacement

It is recommended that the supercharger drive belt be checked at every regular service and be replaced at 50,000 km (30,000 miles) or 2 years, whichever occurs first

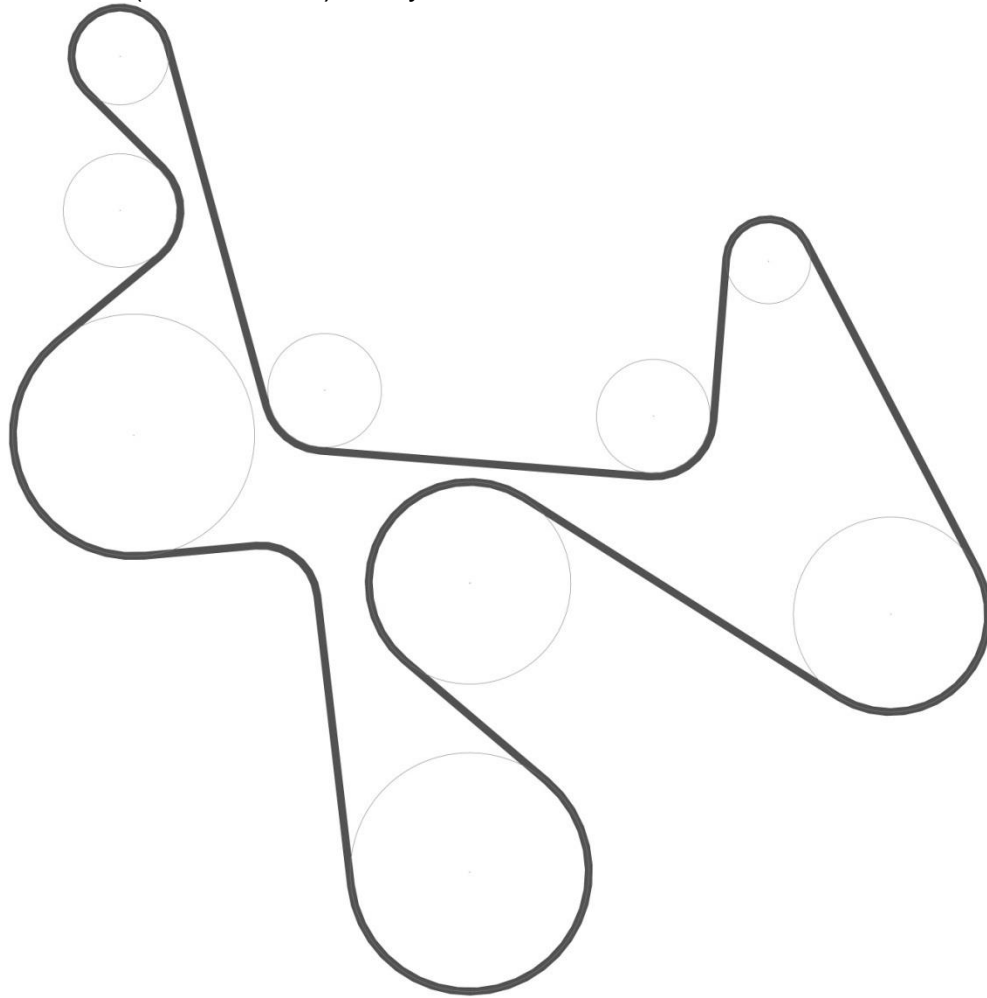

Use long series 3/8" breaker bar to release the dynamic tensioner and remove the belt.

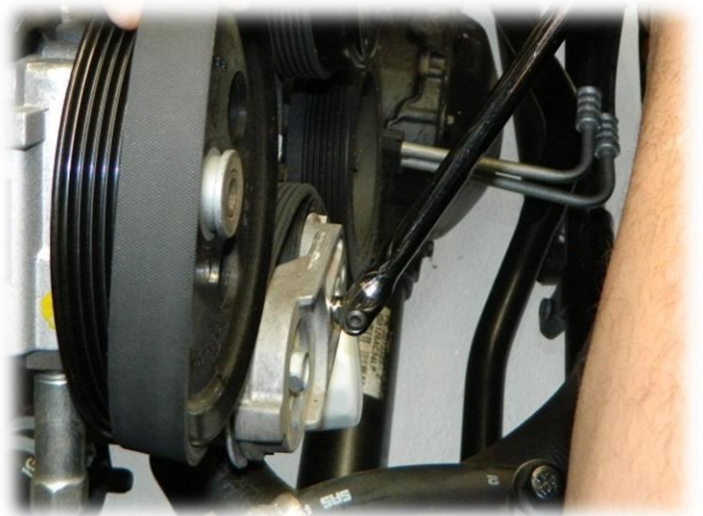

2. Supercharger Lubrication Service

- Drain and replace the supercharger oil every 50,000 km or 30,000 miles, use a quality fully synthetic SAE 75W-90 gear oil, specifications: API GL5, MT1 such as: Redline 75W90 NS gear oil (factory fill), Castrol Syntrax Universal Plus 75W-90, Lucas synthetic SAE 75W-90 gear oil or equivalent.
- Place a suitable receptacle under the drain plug at front underside of the supercharger extension housing. Remove drain plug & fill plug & allow oil to drain fully.
- Refit the bottom drain plug.
- Refill with fully synthetic SAE 75W-90 gear oil, specifications: API GL5, MT1 such as: Redline 75W90 NS gear oil (factory fill), Castrol Syntrax Universal Plus 75W-90, Lucas synthetic SAE 75W-90 gear oil or equivalent.
- through the fill plug. It is critical not to overfill gearbox as damage will occur. Fill with exactly **100 millilitres or 3.38 US fluid ounces**.
- Refit the fill plug with Loctite 577.

NOTE:

The oil level should be regularly inspected by checking oil is visible in the sight glass mounted on the front of the supercharger front case.

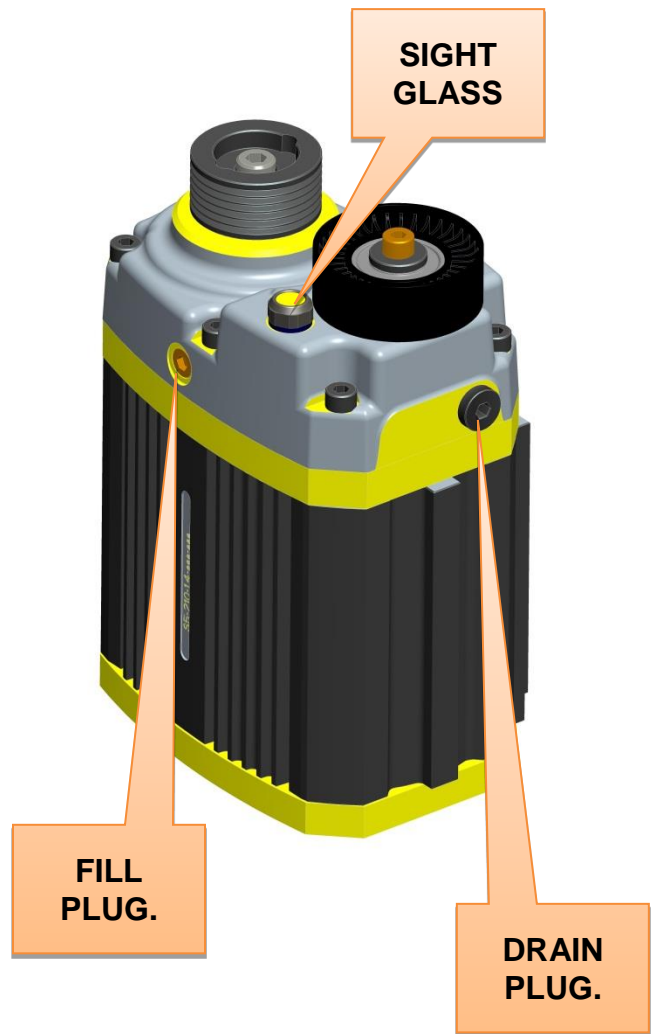

3. Supercharger Service

Sprintex recommends that the supercharger be serviced every 150,000 km. This entails a replacement of all bearings and seals.

<u>Document No.</u>	251D1003
<u>Title</u>	2007 - 2011 3.8L V6 NON-INTERCOOLED SUPERCHARGER SYSTEM
<u>Revision.</u>	2.1
<u>Approved by.</u>	Adrian de Kock
<u>Date.</u>	

