

WeatherTech®

Easy-On™ Stone & Bug Deflectors

Important Safety Information



- CAUTION - Before driving, ensure that the hood shield is properly anchored to vehicle.
- Do not use automatic “brush-style” car washes.
- Do not use cleaning solvents of any kind.
- Periodically check all components for tightness.

Contents **NOTE:** Actual product may vary from illustration.



Hood Shield



Alcohol Pad x2



Washer x4



Self Tapping
Screw x4



Bump On x4

Tools Required



Car Wash Supplies



Clean Towel

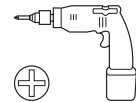

Appropriate hand tools

Preparation Before Painting / Installation

- A trial fit is recommended to ensure proper positioning and fit.
- Check fit of parts before painting as we will not accept the return of modified or painted parts.
- Wash your vehicle’s hood to remove any debris and/or dirt.
- Dry the hood with a clean towel.

Installation Steps **NOTE:** Actual application may vary slightly from illustrations.

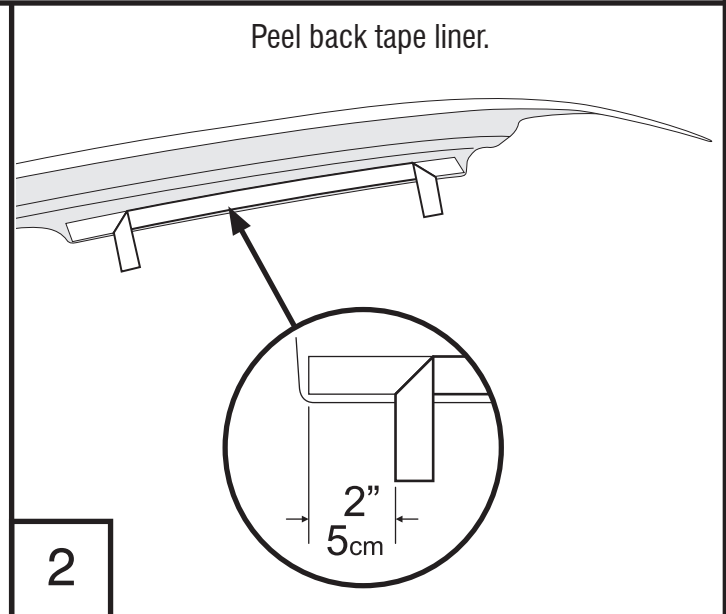
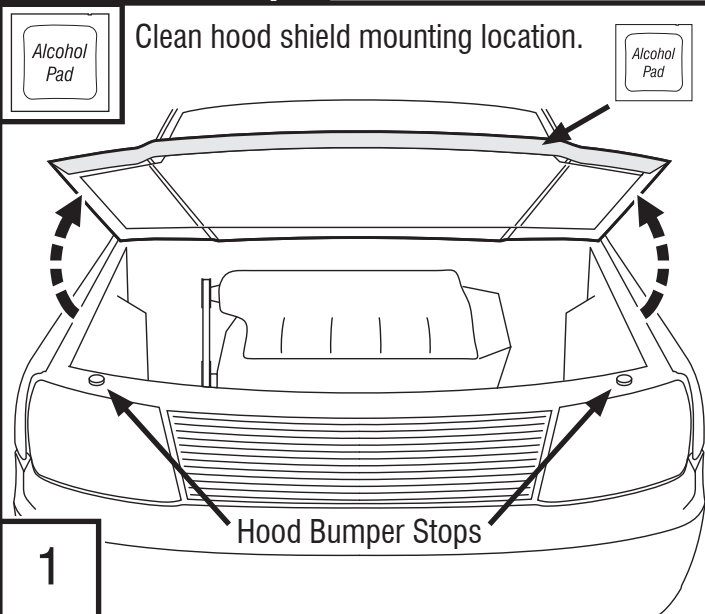

Installation Steps

NOTE: Actual application may vary slightly from drawings.

Center hood shield and attach with exposed tape. Remove tape liner.

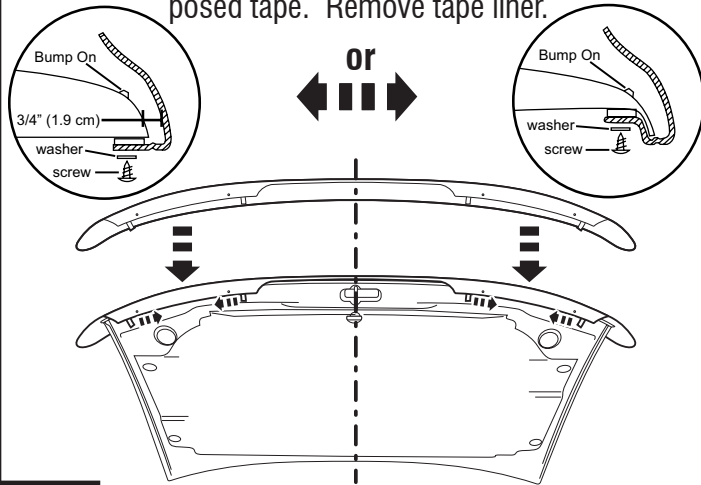

3

NOTE: The hood shield should be offset approximately 3/4" (1.9 cm) from the front edge of hood.

Apply pressure to tape flange.

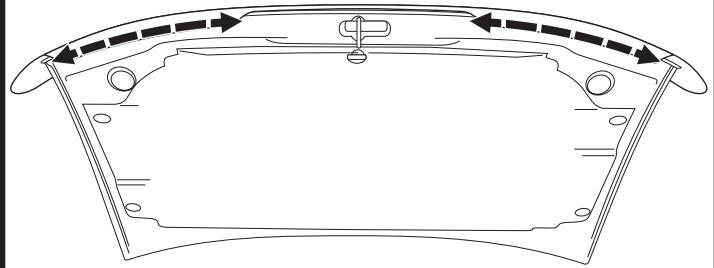

4

NOTE: If applicable position hood shield over trim.
 92-99 Ford Fullsize Van - under trim
 91-96 Ford Escort - discard rubber trim
 99-up F250/350 - discard rubber trim

Optional Screw Attachment

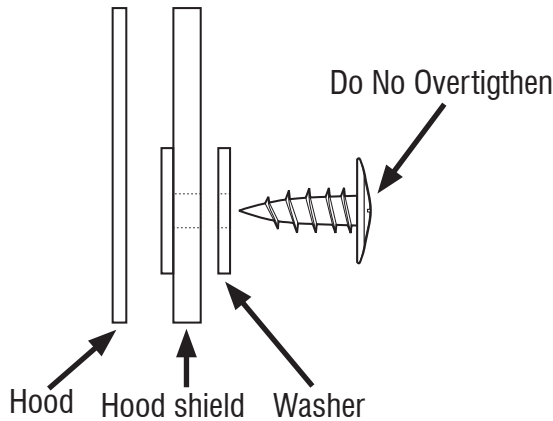

5

91-94 Chevrolet Cavalier uses no screws
 96-up Dodge Caravan/Plymouth Voyager uses (2) screws only



Lower hood, adjust hood bumper stops if necessary. Apply bump-ons to hood surface.

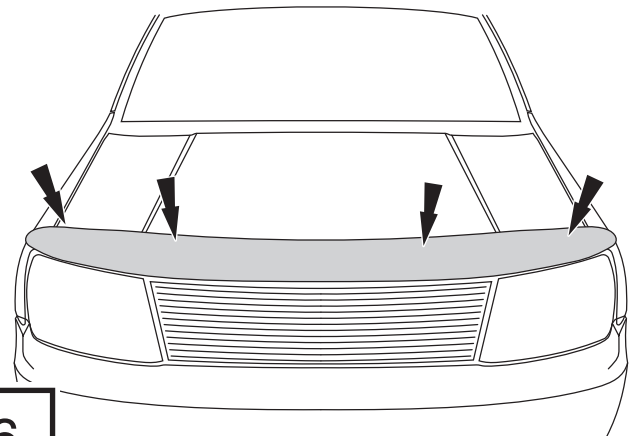

6

Care and Cleaning

- Wash only with mild soap & dry with a clean cloth.



1 MacNeil Ct.

Bolingbrook, IL 60515

Questions? Call customer service @ 630.769.1500

Monday - Friday, 9 a.m. to 5 p.m. Central Time

www.WeatherTech.com

WeatherTech®

Easy-On™ Stone & Bug Deflectors

Informations importantes concernant la sécurité



- ATTENTION - Avant de conduire, s'assurer que le pare-insectes est solidement assujéti sur le véhicule.
- Ne pas utiliser les stations de lavage de voitures à brosse.
- Ne pas utiliser de solvants.
- Vérifier régulièrement le serrage des composants..

Contenu **NOTE:** Le produit réel peut changer de l'illustration.



Pare-insectes

Tampons à l'alcool (2)

Rondelles (4)

Vis taraudeuses (4)

Butoirs (4)

Outils nécessaires



Fournitures pour lavage de voiture



Serviette propre

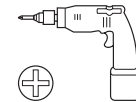

Outils à main appropriés

Préparation pour la peinture/l'installation

- Il est recommandé de procéder à un essai pour s'assurer que le positionnement et l'ajustement sont corrects.
- Vérifier l'ajustement des pièces avant peinture, car nous n'acceptons pas le retour de pièces modifiées ou peintes.
- Laver le véhicule pour éliminer toute poussière et tous débris.
- Sécher le capot avec une serviette propre.

Étapes d'installation **REMARQUE:** La méthode d'application peut être légèrement différente de celle représentée par les illustrations.

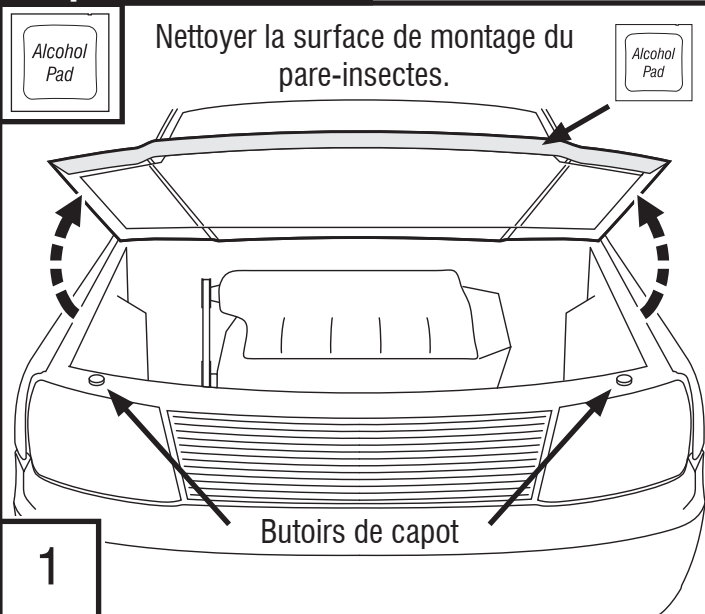

1

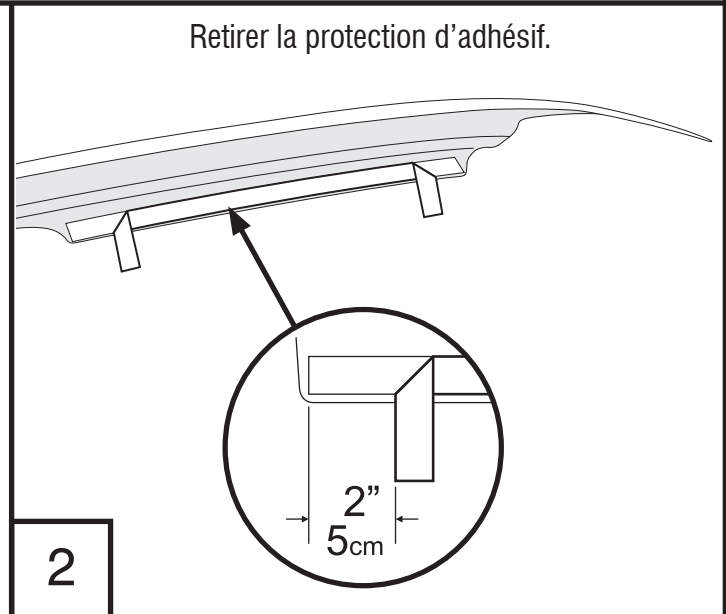

2

Étapes d'installation

REMARQUE : La méthode d'application peut être légèrement différente de celle représentée par les illustrations.

Bouclier et attache centraux de capot avec la bande exposée. Enlevez le recouvrement de bande.

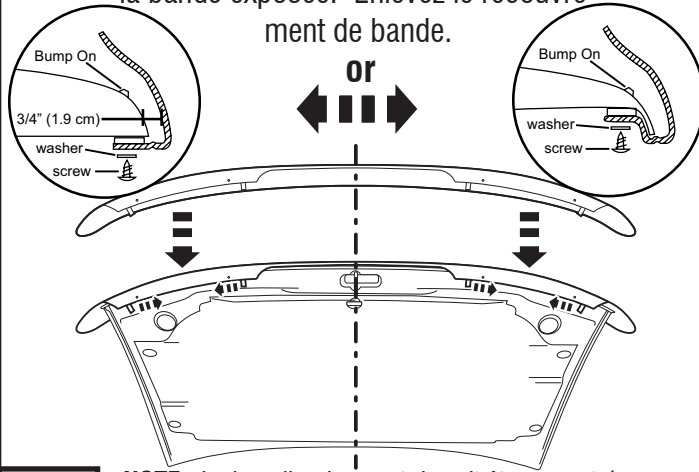

3

NOTE: Le bouclier de capot devrait être excentré approximativement 3/4" (1,9 centimètres) à partir du bord avant du capot.

Appuyer fortement sur l'adhésif.

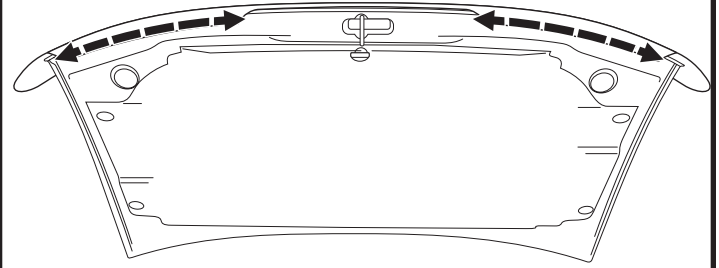

REMARQUE : Le cas échéant, placer le pare-insectes sur la garniture.

4

92-99 Fourgon Ford standard – sous la garniture
91-96 Ford Escort – jeter la garniture en caoutchouc
F250/350 99 et suivants – jeter la garniture en caoutchouc

Fixation optionnelle par vis

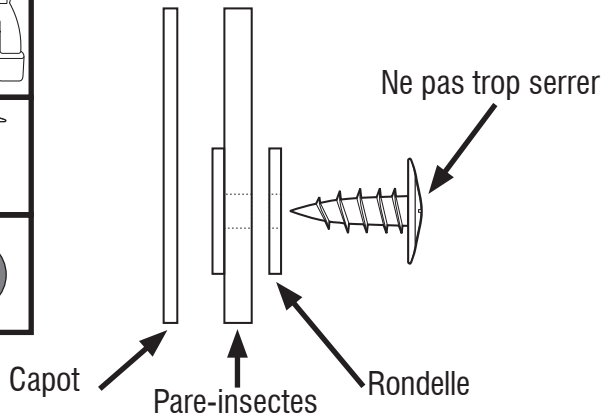

Les modèles Chevrolet Cavalier 91 à 94 n'utilisent pas de vis
Les modèles Caravan/Plymouth Voyager n'utilisent que (2) vis.

5



Abaisser le capot, ajuster les butoirs selon le besoin. Appliquer les butoirs sur le capot.

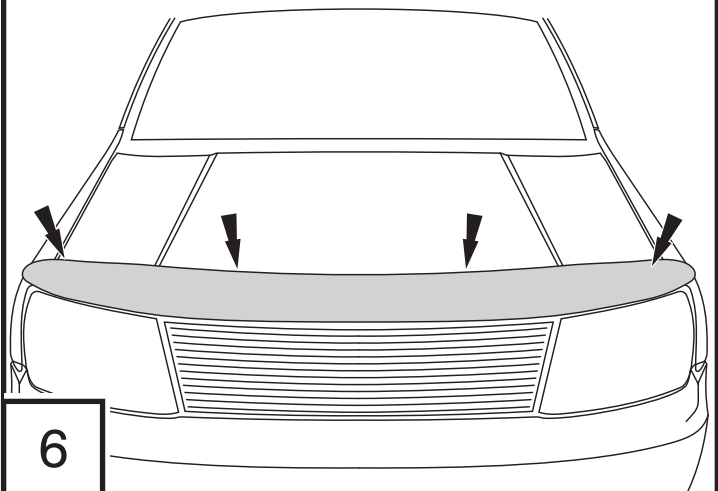

6

Entretien et nettoyage

- Laver exclusivement avec de l'eau savonneuse et sécher avec un chiffon propre.



1 MacNeil Ct.

Bolingbrook, IL 60515

Questions? Call customer service @ 630.769.1500

Monday - Friday, 9 a.m. to 5 p.m. Central Time

www.WeatherTech.com

WeatherTech®

Easy-On™ Stone & Bug Deflectors

Información importante de seguridad



- PRECAUCIÓN - Antes de conducir, asegúrese de que la cubierta para capó esté correctamente anclada al vehículo.
- No utilice servicios automáticos de limpieza de vehículos que utilizan cepillos.
- No utilice limpiadores al solvente de ningún tipo.
- Compruebe periódicamente que todos los componentes estén ajustados.

Contenido **NOTA:** El producto real puede variar de la ilustración.



Cubierta para capó



Paño esterilizado x 2



Arandela x 4



Tornillo autorroscante x 4



Soporte x 4

Herramientas necesarias



Equipo de limpieza de vehículos



Toalla limpia

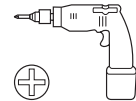

Herramientas manuales adecuadas

Preparación antes de pintar o instalar

- Se recomienda realizar un ajuste de prueba para asegurar el posicionamiento y ajuste correctos.
- Compruebe que las piezas se ajusten correctamente antes de pintarlas, ya que no aceptaremos la devolución de piezas modificadas o pintadas.
- Lave el capó del vehículo para quitar los desechos y la suciedad.
- Seque el capó con una toalla limpia.

Pasos de instalación **NOTA:** El uso real puede variar levemente de ilustraciones.

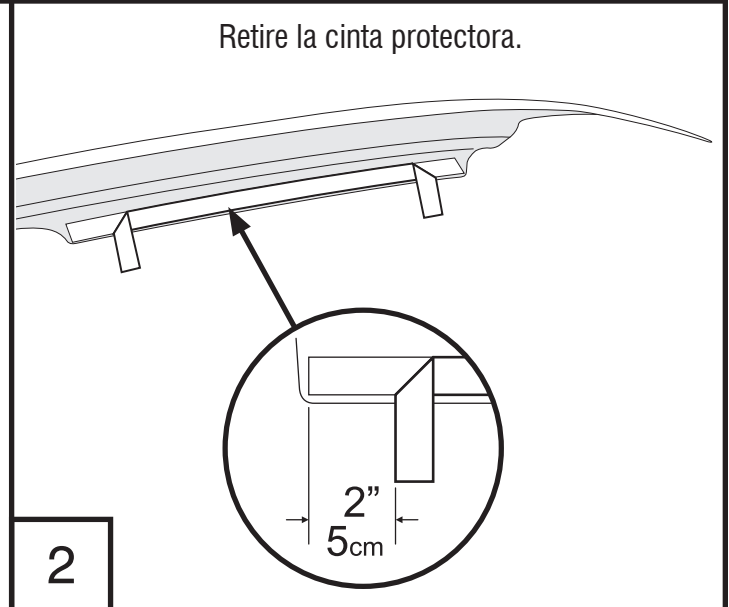
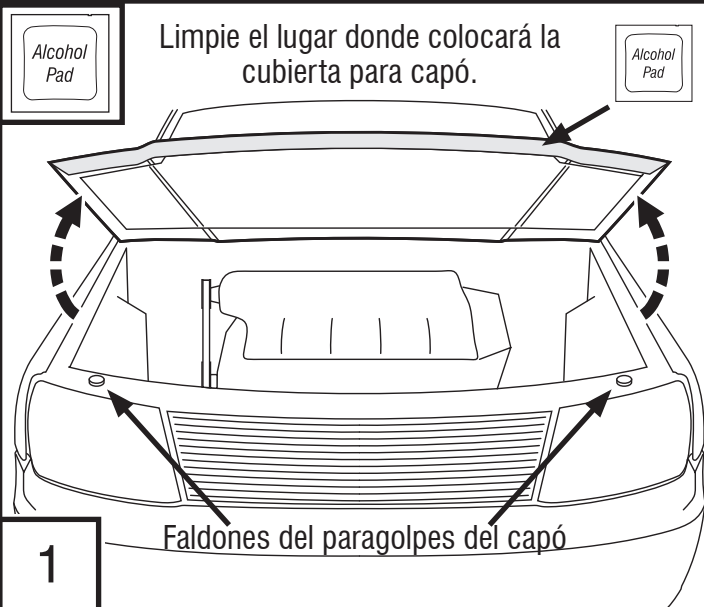

Pasos de instalación

AVISO: La colocación real puede variar levemente con respecto a las ilustraciones.

Protector y fijación de centro de la capilla con la cinta expuesta. Quite el trazador de líneas de la cinta.

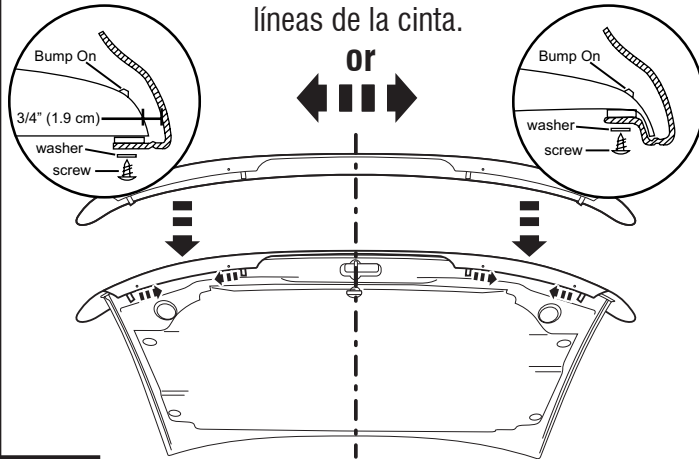

3

NOTA: El protector de la capilla se debe compensar el aproximadamente 3/4" (1,9 centímetros) del borde delantero de la capilla.

Presione sobre el reborde de la cinta.

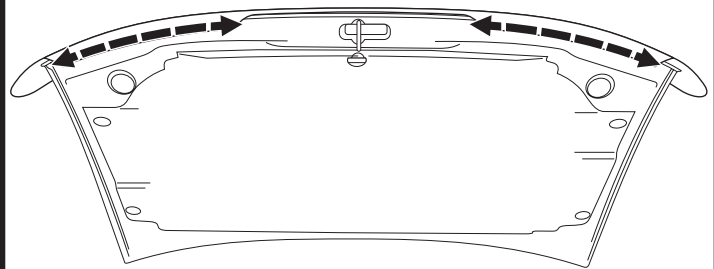

AVISO: Si fuera necesario, coloque la cubierta para capó sobre la banda.

4

Camioneta Ford de gran tamaño 92 a 99 – por debajo de la banda
Ford Escort 91 a 96 – deseche la banda de goma
F250/350 99 y posteriores – deseche la banda de goma

Colocación del tornillo opcional

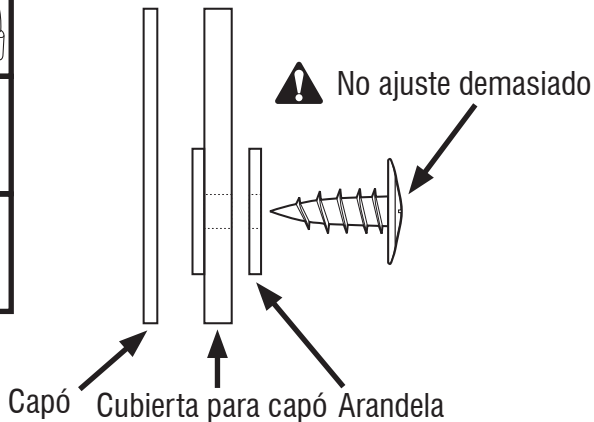

5

Para Chevrolet Cavalier 91 a 94 no se necesitan tornillos
Para Dodge Caravan/Plymouth Voyager 96 y posteriores se necesitan (2) tornillos solamente



Baje el capó y ajuste los faldones del paragolpes del capó y ajuste los faldones del paragolpes del capó si es necesario. Coloque los soportes en la superficie del capó.

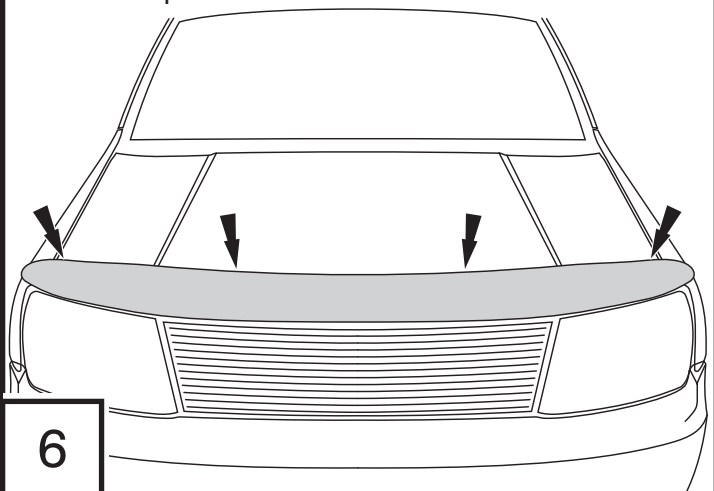

6

Cuidado y limpieza

- Limpie solamente con agua jabonosa tibia y seque con un paño limpio.



1 MacNeil Ct.

Bolingbrook, IL 60515

Questions? Call customer service @ 630.769.1500

Monday - Friday, 9 a.m. to 5 p.m. Central Time

www.WeatherTech.com