

Hurricane Flat Fender Flares

PATENT PENDING

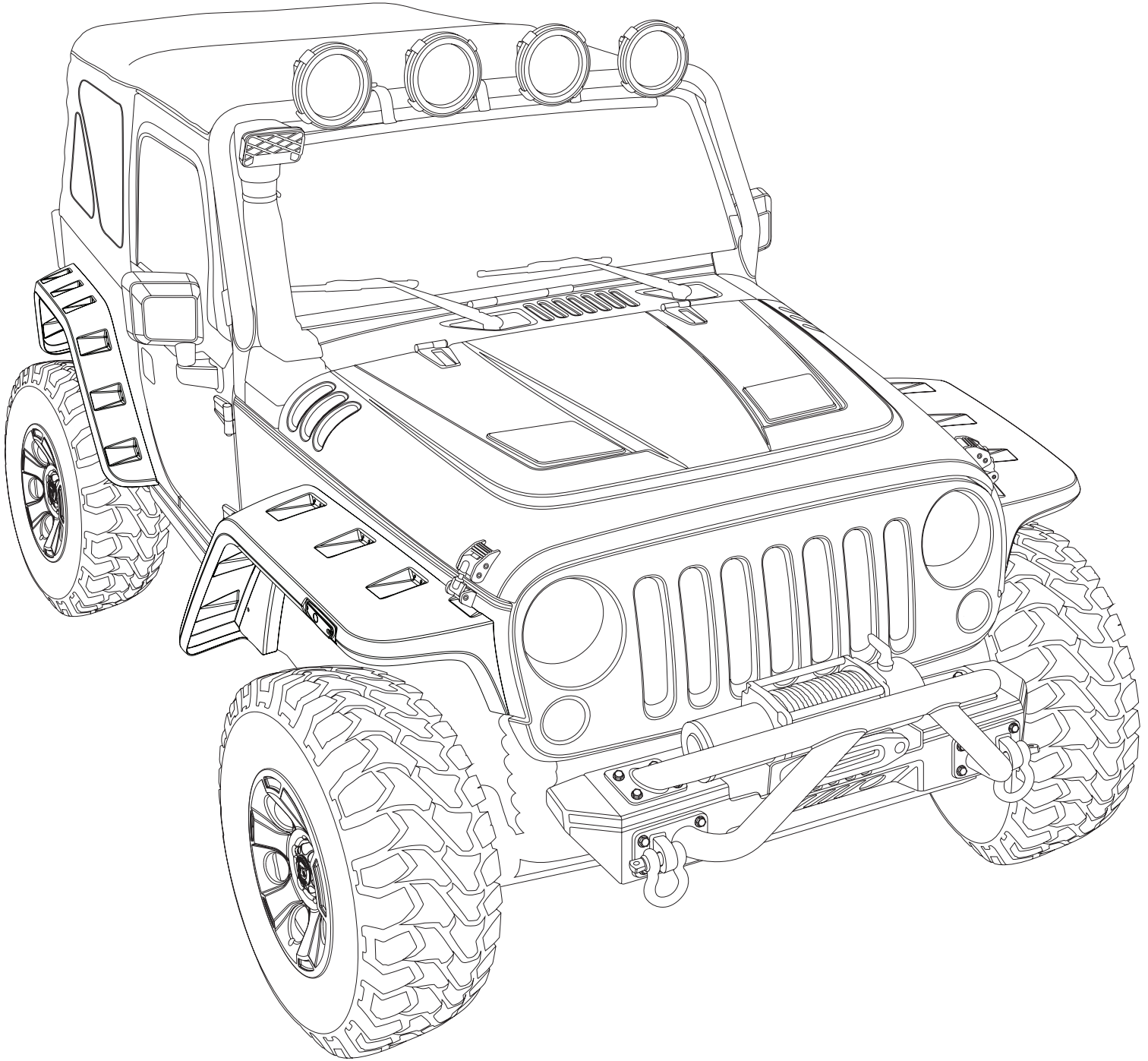

OMIX-ADA® TECHNICAL SUPPORT

PHONE: M-F 8am - 5pm EST 1-800-449-6649 | **EMAIL:** techsupport@omix-ada.com

FOR WARRANTY INFORMATION VISIT: www.Omix-Ada.com



OMIX-ADA, Inc.

11640.10

Hurricane Flat Fender Flares PATENT PENDING

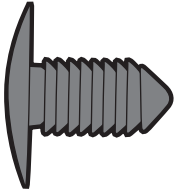

10mm Shield Retainer x 24

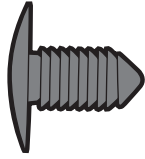

8mm Shield Retainer x 2

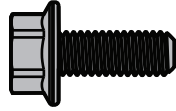

M6 Flange Bolt x 26

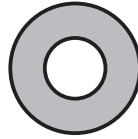

16mm Washer x 12

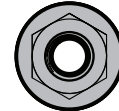

M6 Nut x 26

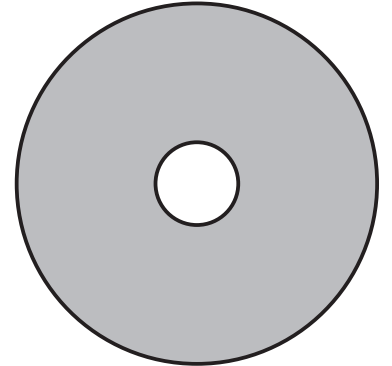

45mm Washer x 12

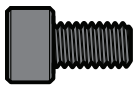

Decorative Black Bolt x 56



Black Nut x 56



Nylon Nut x 4

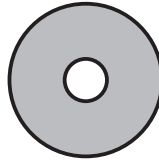

20mm Washer x 4



M4 Bolt x 4

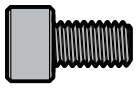

Decorative Stainless Steel Bolt x 56



Stainless Steel Nut x 56



Zip Tie x 2



Black Wire x 2



Butt Connector x 4



White Wire x 2



Female Terminal x 4

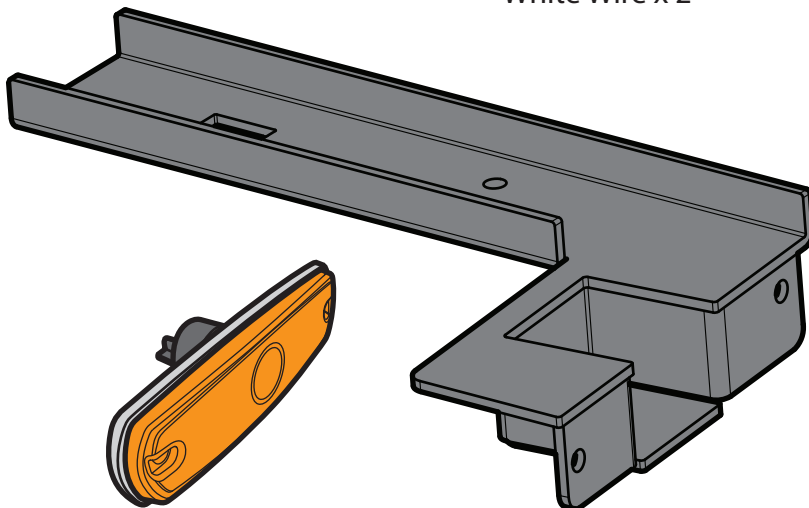

Side Marker Light x 2

Support Bracket x 2

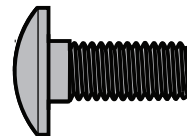

M8 Carriage Bolt x 2

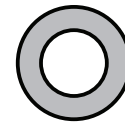

16mm Washer x 2

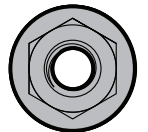

M8 Nut x 2



M4 Nut x 4



9mm Washer x 4



M4 Bolt x 4



OMIX-ADA, Inc.



11640.10

Hurricane Flat Fender Flares PATENT PENDING

1. Remove the front & rear factory fender flare, flare support and wheel liner.

Remove factory fasteners with a flat head screw driver or similar.

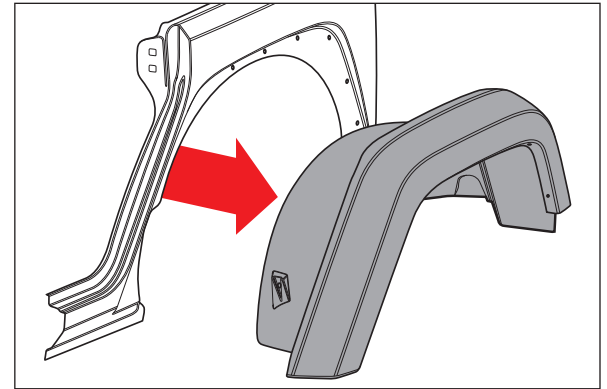
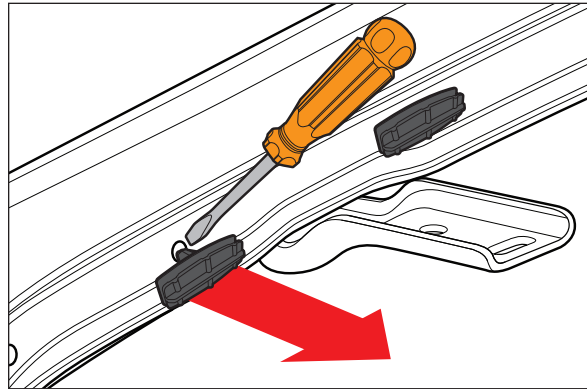
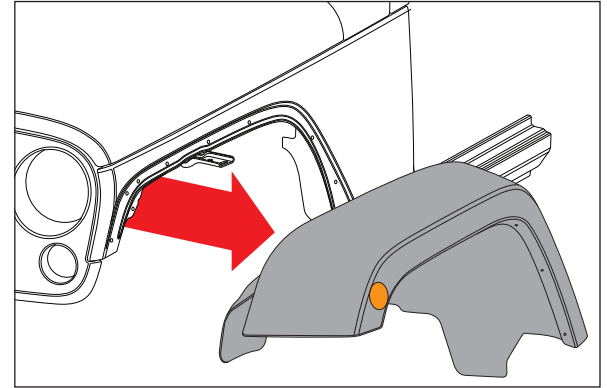

2. Cut side marker off 2 inches from the base of light fixture.

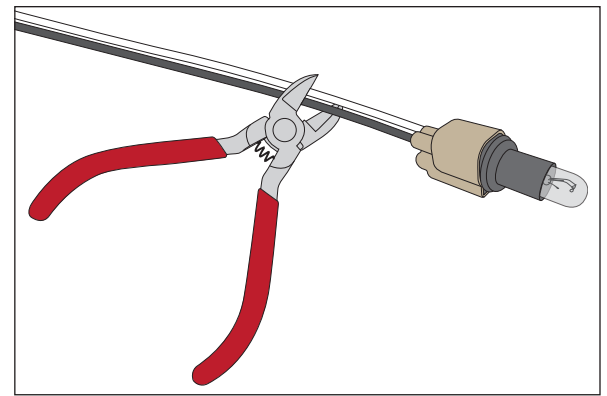

3. Strip 1/4" from wires previously cut. Strip 1/4" from both ends from wires supplied in hardware kit.

Splice wires cut using the butt connectors and wires supplied.

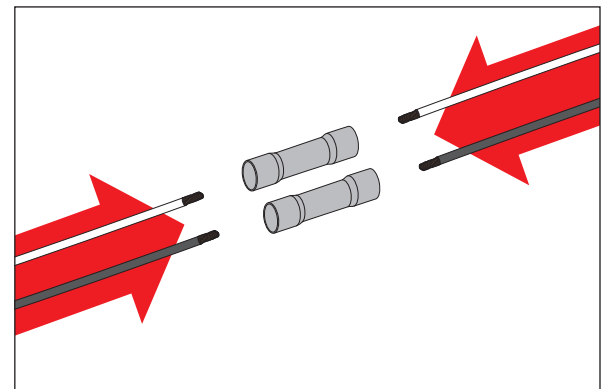



OMIX-ADA, Inc.



11640.10

Hurricane Flat Fender Flares PATENT PENDING

4. Attach and crimp female terminals to wires.

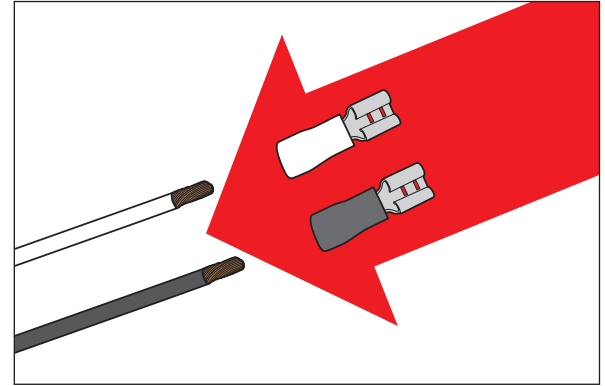

5. Insert female terminals into side marker lights supplied.

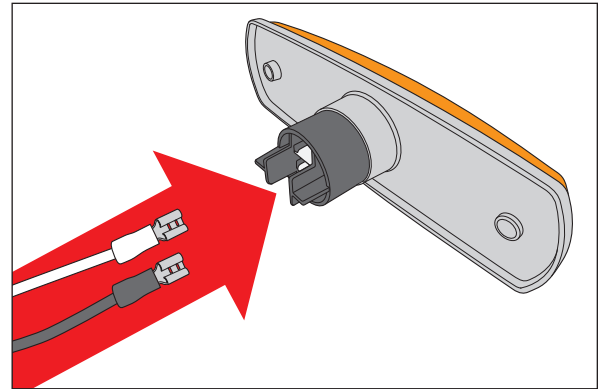

6. Attach support arm to fender with M8 carriage bolt, 16mm washer and M8 nut..

NOTICE Do not tighten. Support Arm should point forward.

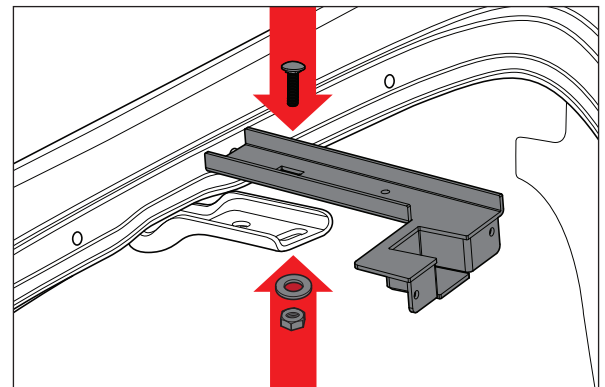

7. Attach side marker light to support arm with M4 bolt, 9mm washer and M4 nut.

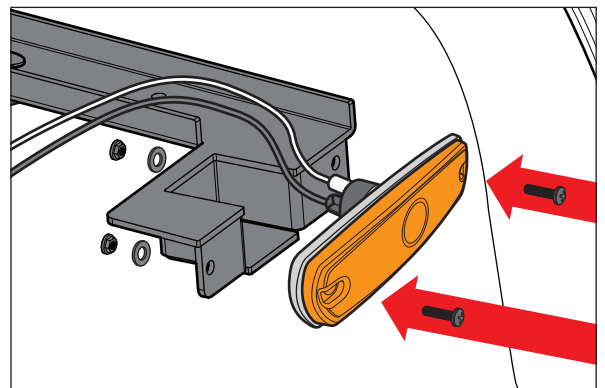



OMIX-ADA, Inc.



11640.10

Hurricane Flat Fender Flares PATENT PENDING

8. Secure wires to support arm with zip tie.

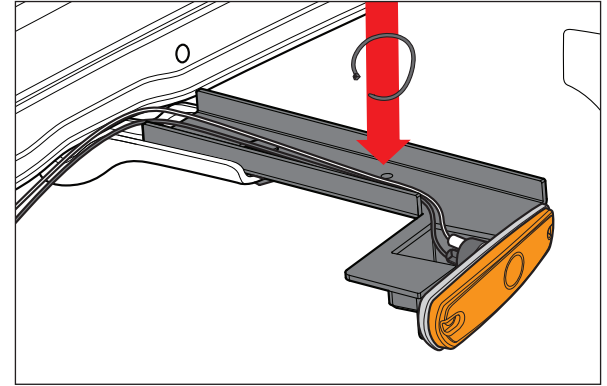

9. Loosely fasten flare to the side of the fender using 2 M6 flange bolts and M6 nuts.

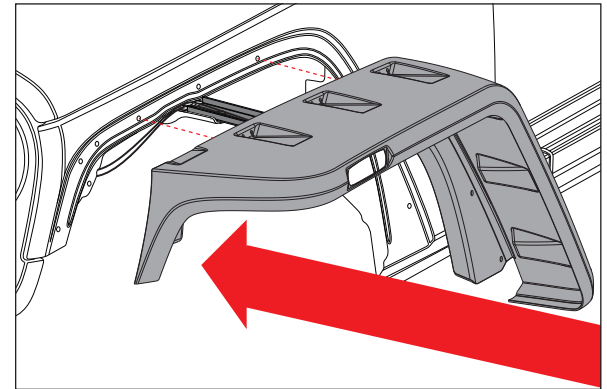

10. Mark your fender using the hole shown as a guide. Remove fender flare after fender is marked.

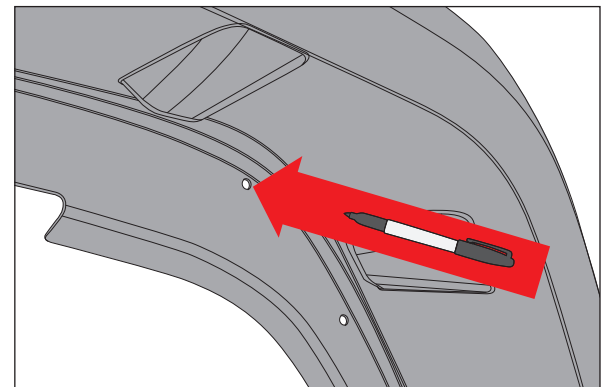

11. Using an 11/32 drill bit, drill into the fender where you previously marked.

NOTICE

Paint edge of hole cut to prevent rust.

CAUTION

Cutting/Sharp Edge Hazard: Cut carefully using gloves and eye protection.

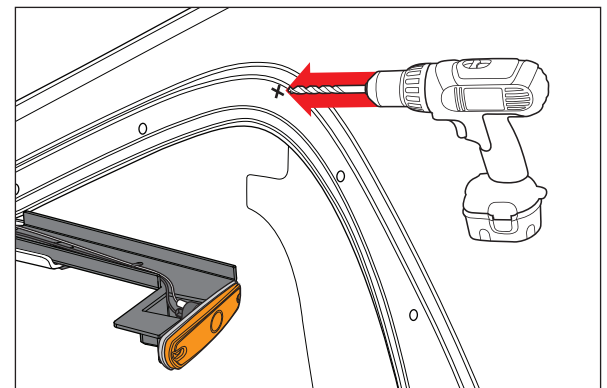



OMIX-ADA, Inc.



11640.10

Hurricane Flat Fender Flares PATENT PENDING

12. Attach front wheel liner, mark a line that follows the edge of the fender. Cut the line marked. **If you do not have a Rugged Ridge Snorkel skip to Step 14.**

CAUTION Cutting/Sharp Edge Hazard: Cut carefully using gloves and eye protection.

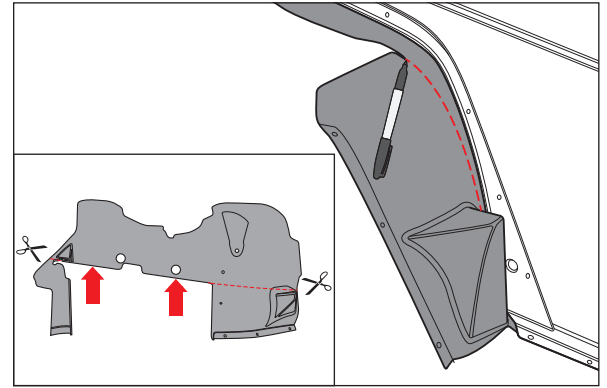

13. If you have a Rugged Ridge Snorkel, mark passenger side wheel liner where indicated. Carefully cut area marked.

CAUTION Cutting/Sharp Edge Hazard: Cut carefully using gloves and eye protection.

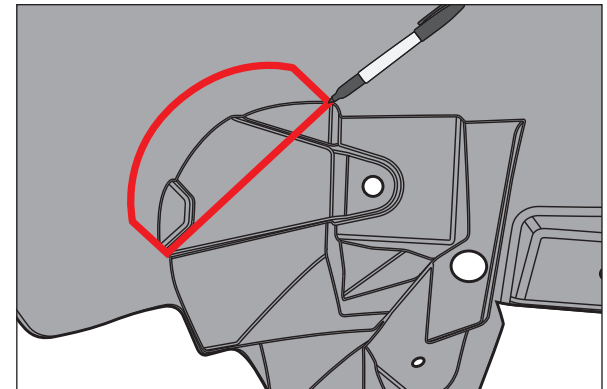
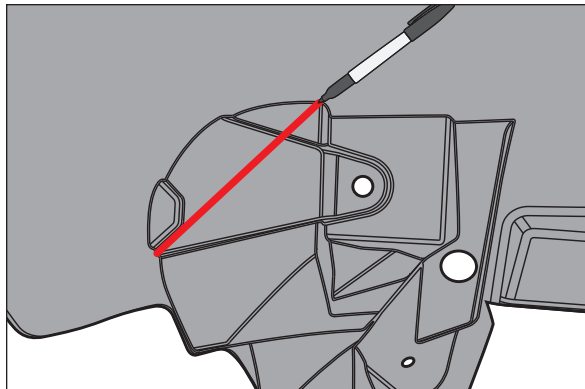
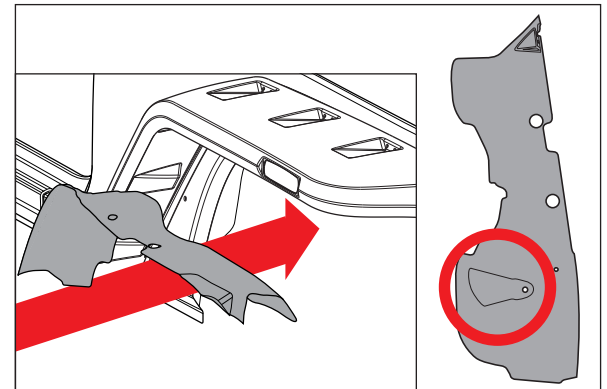

14. Secure flare with M6 flange bolts, 45mm washers and M6 nuts where **Green Arrows** indicate.

Secure M6 flange bolts, 16mm washers and M6 nuts where the **Red Arrows** indicate.

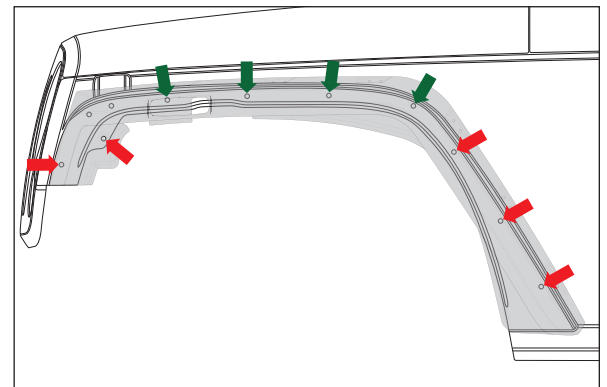



OMIX-ADA, Inc.



11640.10

Hurricane Flat Fender Flares PATENT PENDING

15. Place and position cut front liner in wheel well.

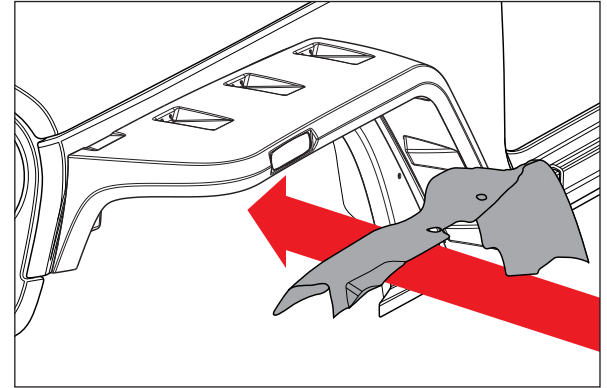

16. Use factory screws previously removed and 45mm washers to secure wheel liner where **Red Arrows** indicate.

Replace factory nut where **Green Arrow** indicates.

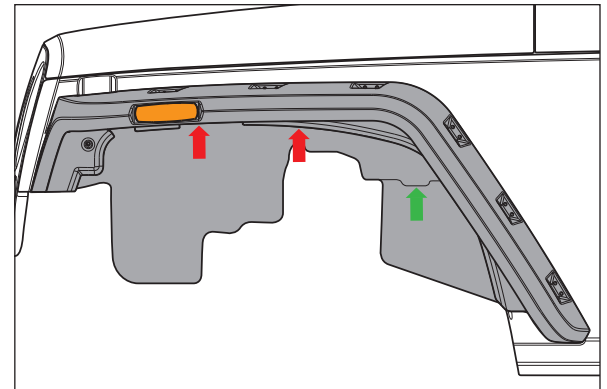

17. Attach rear wheel liner, mark a line that follows the edge of the fender. Cut the line marked. **2 Door JK Owners Skip to Step 19**

CAUTION Cutting/Sharp Edge Hazard: Cut carefully using gloves and eye protection.

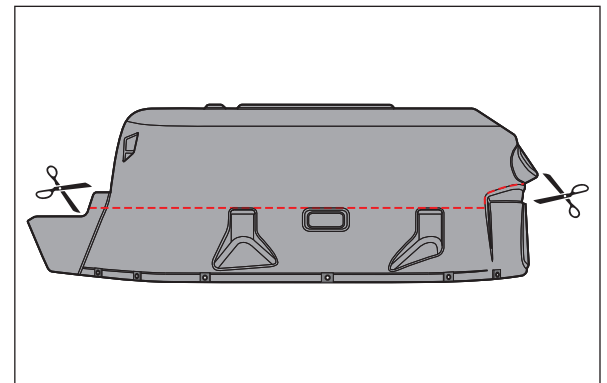
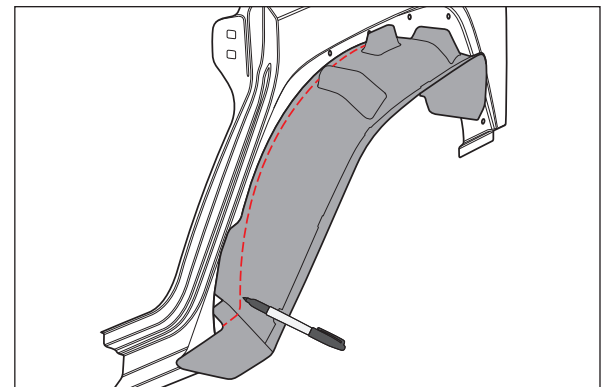



OMIX-ADA, Inc.

11640.10

Hurricane Flat Fender Flares PATENT PENDING

18. Attach and tighten Hurricane flare with M6 flange bolts, 16mm washers and M6 nuts where the **Red Arrows** indicate.

Secure rest of the flare with large push fasteners where **Green Arrows** indicate. **Skip to Step 20**

NOTICE If 10mm shield retainers don't go into designated holes, use a 3/8 drill bit to widen the holes designated by the **Green Arrows**. Paint edge of hole cut to prevent rust.

CAUTION Cutting/Sharp Edge Hazard: Cut carefully using gloves and eye protection.

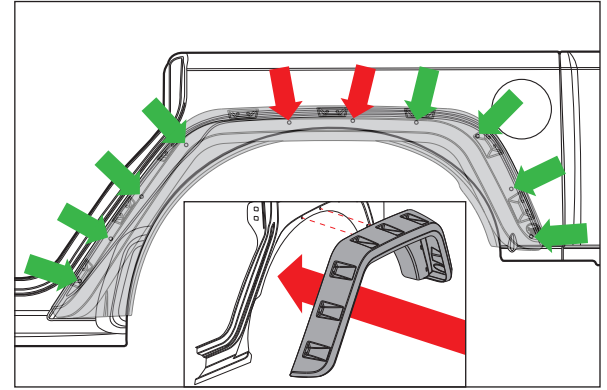

19. Insert nylon nuts in two holes indicated.

Attach Hurricane Flare with M6 flange bolts, 16mm washers and M6 nuts where **Red Arrows** indicate.

Figure 2 shows how to secure flare with M4 bolts, 20mm washers, and nylon nuts indicated by **Purple Arrows** found in **Figure 1**.

Secure remaining flare with 10mm shield retainers indicated by **Green Arrows**.

NOTICE If 10mm shield retainers don't go into designated holes, use a 3/8 drill bit to widen the holes designated by the **Green Arrows**. Paint edge of hole cut to prevent rust.

CAUTION Cutting/Sharp Edge Hazard: Cut carefully using gloves and eye protection.

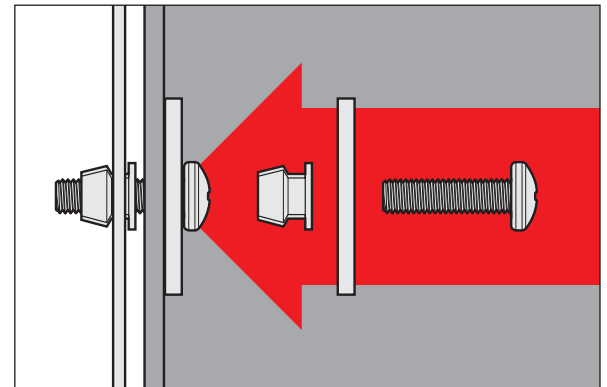
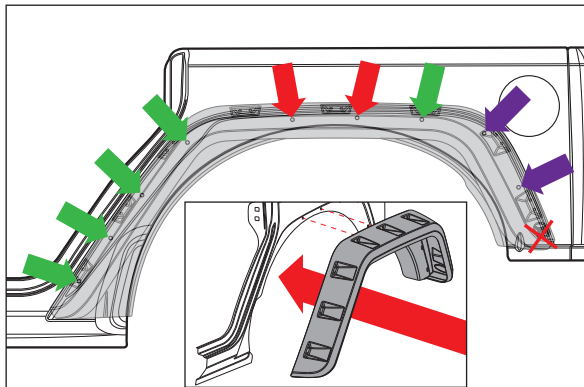
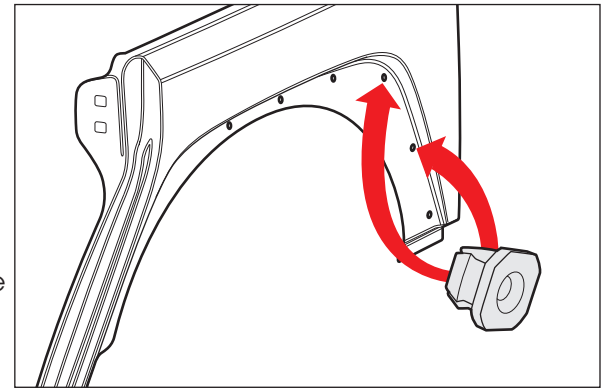

20. Place rear wheel liner into wheel well.

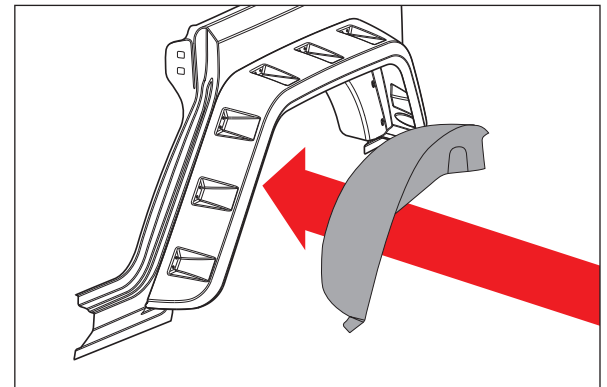



OMIX-ADA, Inc.



11640.10

Hurricane Flat Fender Flares PATENT PENDING

21. Secure wheel liner using M6 flange bolts, 16mm washers and M6 nuts in locations indicated by **Red Arrows**.

Secure wheel liner with 8mm shield retainer indicated by **Green Arrow**.

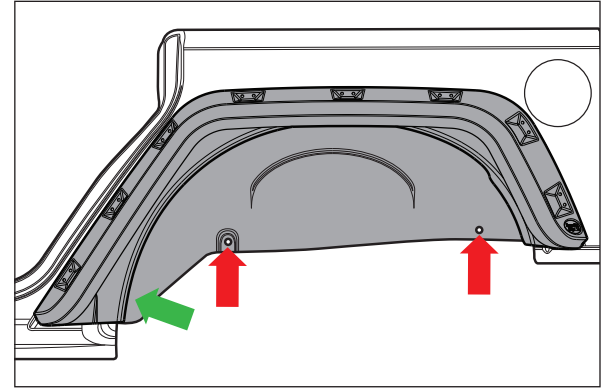

22. Attach your choice of either black or stainless steel decorative bolts into the double pockets.

