

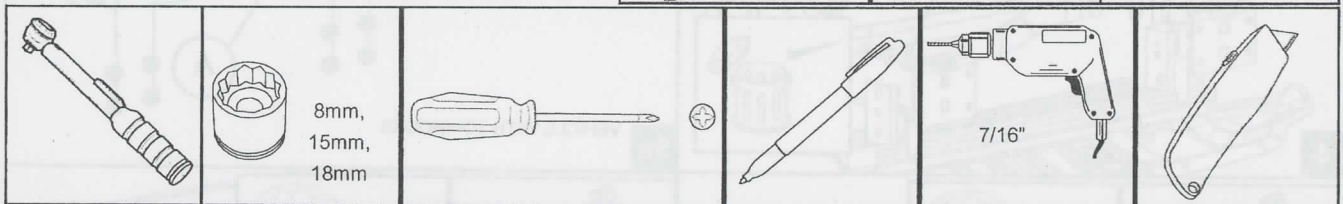

FRONT BUMPER

1X	A	2X	B	12X	D	2X	F
4X	C	2X	E	2X	G		



*NOTE: VEHICLES WITH FOG LAMPS MUST DISCONNECT AND SECURE WIRE HARNESS TO VEHICLE USING TIE WRAPS OR ELECTRICAL TAPE, NOT INCLUDED IN KIT.
 *NOTE: SAVE OEM BUMPER ASSEMBLY AND FASTENERS FOR RE-INSTALLATION.

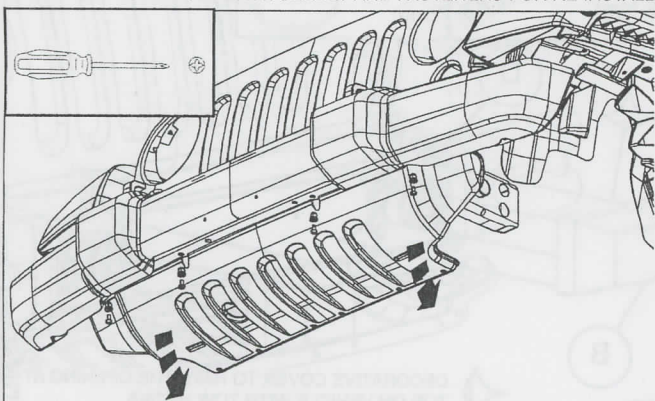

1 REMOVE FOUR (4) PLASTIC FASTENERS IN FRONT AND ROTATE SPLASHSHIELD REARWARD. DO NOT REMOVE REAR FASTENERS.

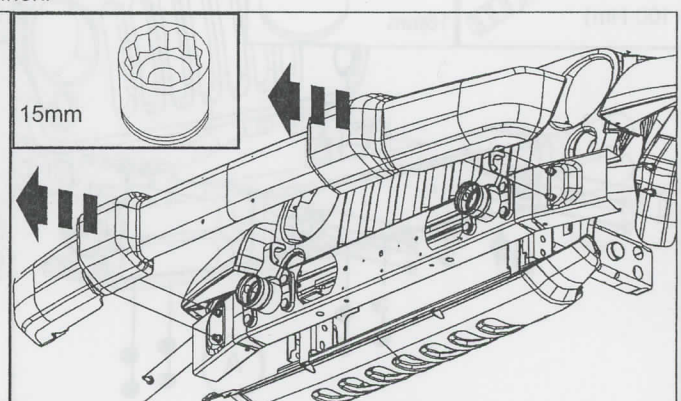

2 REMOVE OUTER (4) SCREWS, 2 PER SIDE, TO DISASSEMBLE FASCIA FROM BUMPER BEAM*

SPLASHSHIELD TO BE MODIFIED FOR INSTALLATION OF TUBULAR FRONT BUMPER

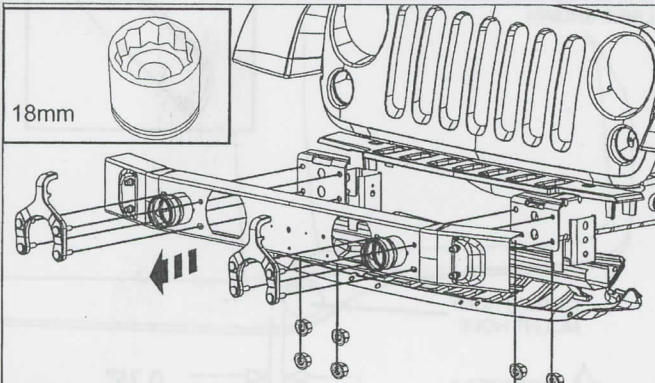

3a VEHICLE WITH TOWHOOKS
SAVE HARDWARE FOR STEP 5A

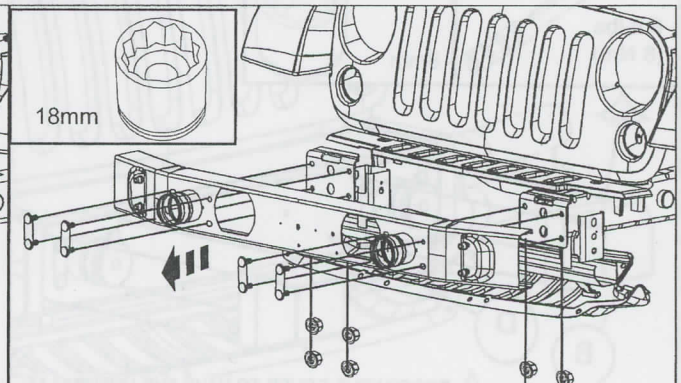

3b VEHICLE WITHOUT TOWHOOKS
SAVE HARDWARE FOR STEP 5B



FRONT BUMPER

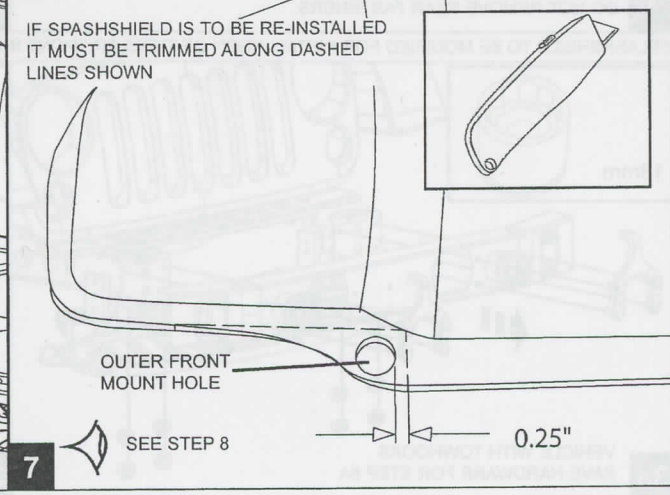
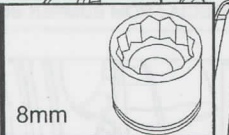
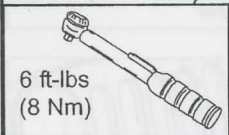
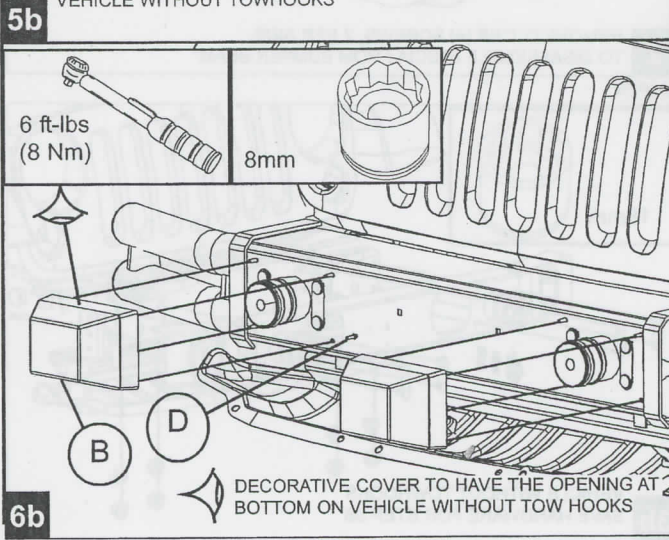
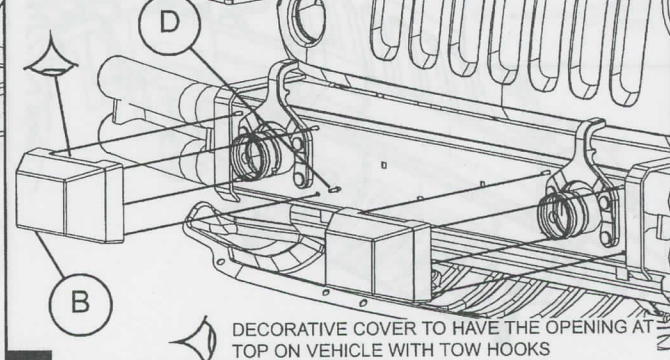
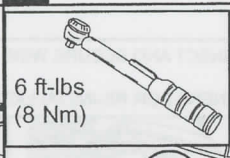
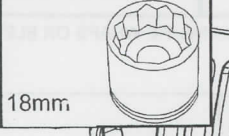
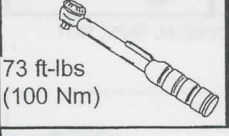
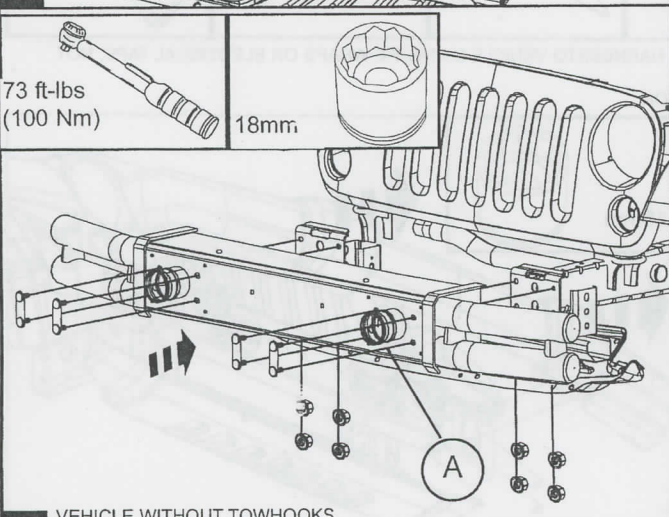
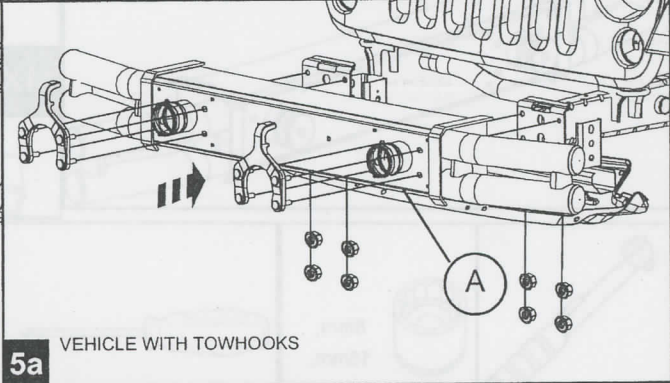
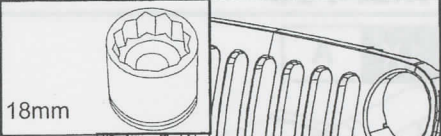
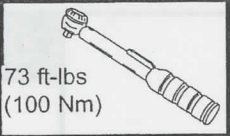
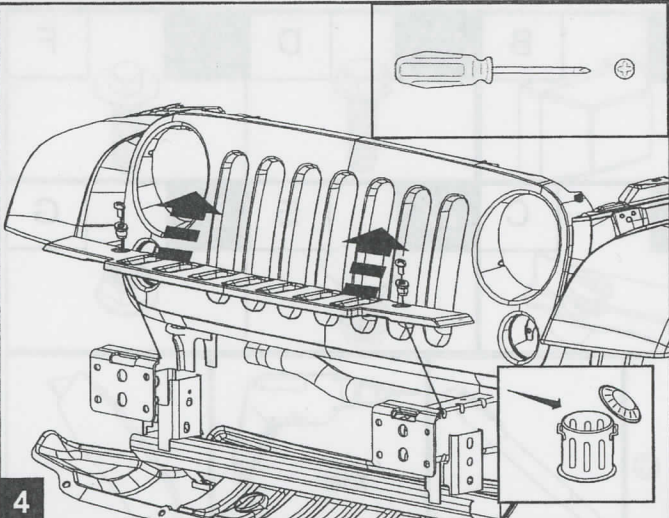



MOPAR.

SEE STEP 7

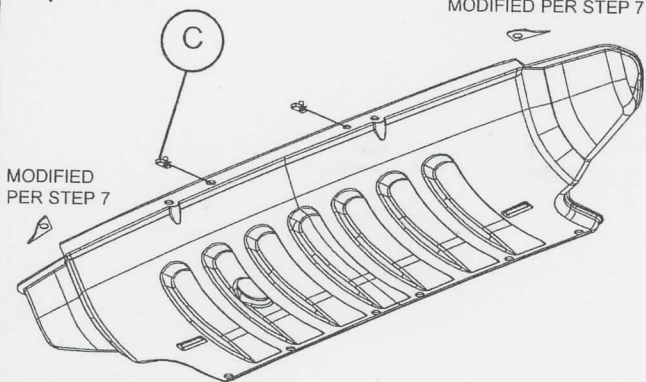

8 INSTALL TWO (2) U-NUTS

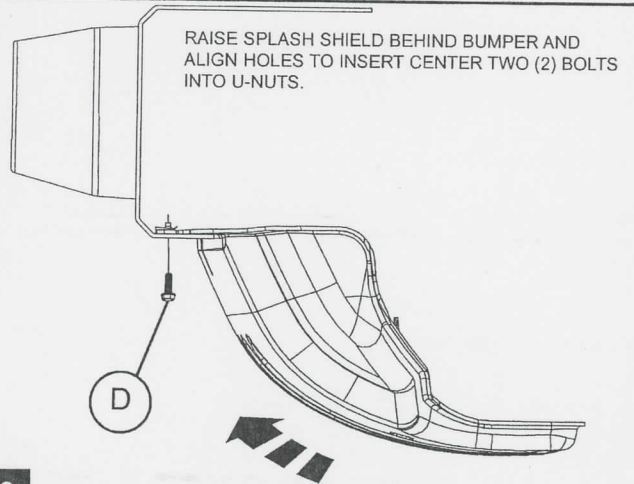

9

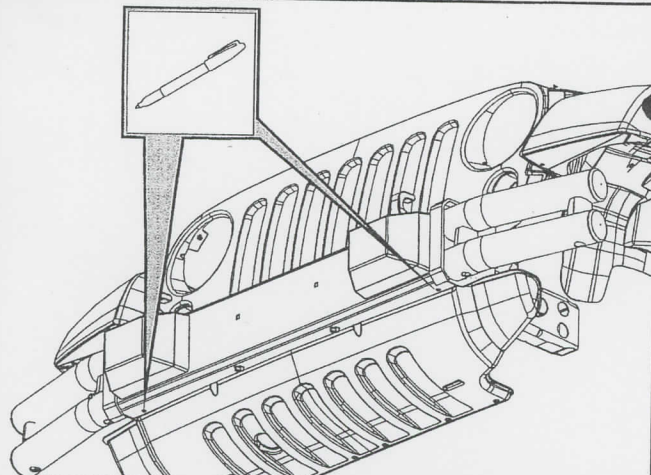

10 USE HOLES IN BUMPER AS A TEMPLATE. MARK THE SPLASH SHIELD TO LOCATE OUTER HOLES. REMOVE SPLASH SHIELD AND DRILL 7/16" DIAMETER HOLES.

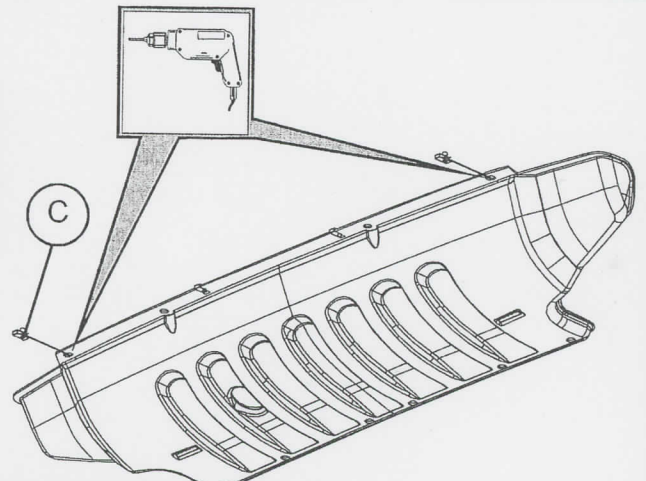

11 DO NOT DRILL THROUGH BUMPER. INSTALL TWO (2) U-NUTS.

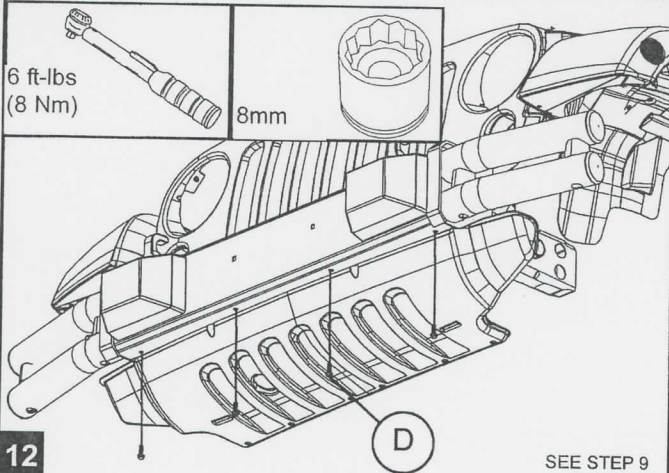

12

SEE STEP 9

SPLASH SHIELD MAY BE TRIMMED MANY WAYS, IT IS UP TO CUSTOMERS DISCRETION FOR DESIRED APPEARANCE.

FOG LAMP REPLACEMENT:
FASCIA WITH FOG LAMPS USE MOPAR PART NUMBER 82209880 (FOG LAMPS KIT) AND 82210549 (WIRING HARNESS KIT).
FASCIA WITHOUT FOG LAMPS USE PART NUMBER 82210217 (FOG LAMP KIT COMPLETE)
PLUG HOLES WITH ITEM "E" FOR NO INSTALLATION OF FOG LAMPS

ROUND HOLES IN BUMPER FACE ARE PROVIDED TO INSTALL LICENSE PLATE USING INCLUDED HARDWARE (ITEMS G & F).

